

金融科技



Tamkang  
University  
淡江大學

FinTech: Financial Technology

金融科技智慧問答系統  
(Intelligent Question Answering  
System for Fintech)

1052FinTech11

MIS EMBA (M2263) (8595)

Fri, 12,13,14 (19:20-22:10) (D409)

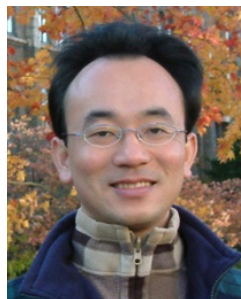

Min-Yuh Day

戴敏育

Assistant Professor

專任助理教授

Dept. of Information Management, Tamkang University

淡江大學 資訊管理學系

<http://mail.tku.edu.tw/myday/>

2017-06-02



# 課程大綱 (Syllabus)

週次 (Week)	日期 (Date)	內容 (Subject/Topics)
1	2017/02/17	Fintech 金融科技課程介紹 (Course Orientation for Fintech: Financial Technology)
2	2017/02/24	Fintech 金融科技的演進：貨幣與金融服務 (Evolution of Fintech: Money and Financial Services)
3	2017/03/03	Fintech 金融科技：金融服務科技創新 (Fintech: Technology Innovation in Financial Services)
4	2017/03/10	Fintech 金融科技與金融服務價值鏈 (Fintech and Financial Services Value Chain)
5	2017/03/17	Fintech 金融科技商業模式創新 (Fintech Business Models Innovation)
6	2017/03/24	Fintech 金融科技個案研究 I (Case Study on Fintech I)

# 課程大綱 (Syllabus)

週次 (Week)	日期 (Date)	內容 (Subject/Topics)
7	2017/03/31	金融服務消費者心理與行為 (Consumer Psychology and Behavior on Financial Services)
8	2017/04/07	教學行政觀摩日 (Off-campus study)
9	2017/04/14	區塊鏈技術 (Blockchain Technology) [Invited Speaker: Dr. Raymund Lin, IBM (林俊叡 博士，IBM)]
10	2017/04/21	期中報告 (Midterm Project Report)
11	2017/04/28	Python Pandas財務大數據分析 (Finance Big Data Analytics with Pandas in Python)
12	2017/05/05	人工智慧與深度學習金融科技 (Artificial Intelligence and Deep Learning for Fintech)

# 課程大綱 (Syllabus)

週次 (Week)	日期 (Date)	內容 (Subject/Topics)
13	2017/05/12	Fintech 金融科技個案研究 II (Case Study on Fintech II)
14	2017/05/19	金融科技財富管理：機器人理財顧問 (Robo-Advisors for Wealth Management in Fintech)
15	2017/05/26	投資組合最佳化與程式交易 (Portfolio Optimization and Algorithmic Trading)
16	2017/06/02	金融科技智慧問答系統 (Intelligent Question Answering System for Fintech)
17	2017/06/09	期末報告 I (Final Project Presentation I)
18	2017/06/16	期末報告 II (Final Project Presentation II)



# **Intelligent Question Answering System for Fintech**

# FinTech Innovation: From Robo-Advisors to Goal Based Investing and Gamification, Paolo Sironi, Wiley, 2016

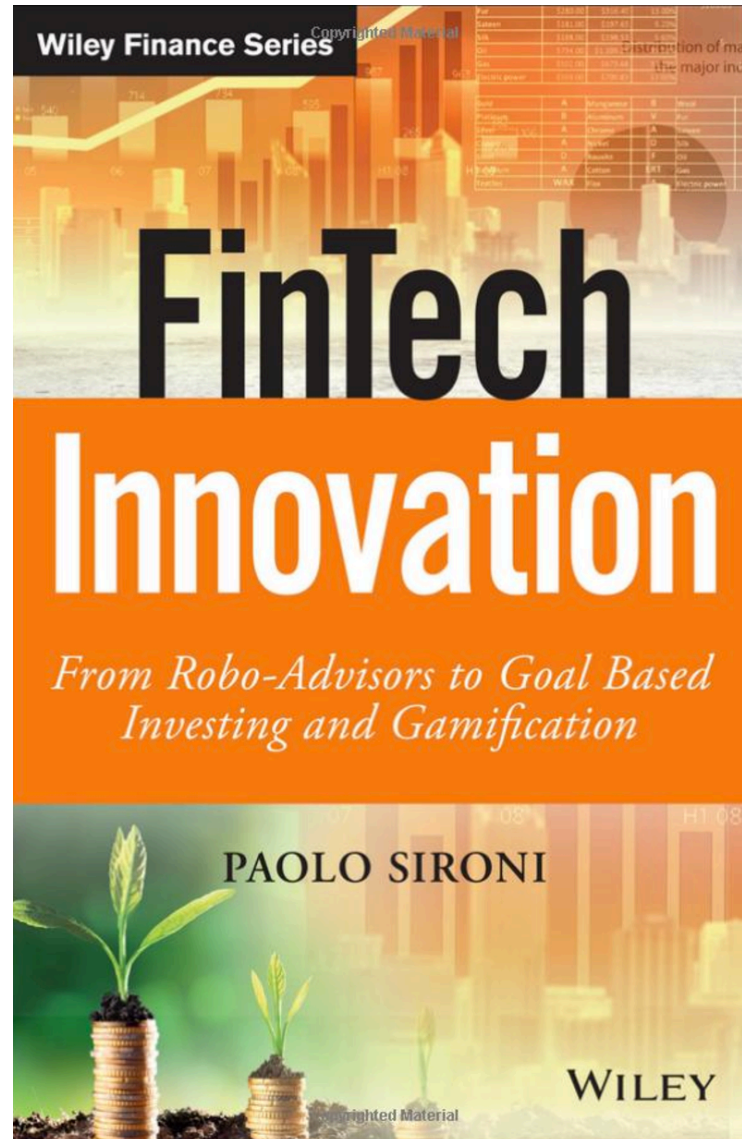

# FinTech: Financial Services Innovation



# FinTech:





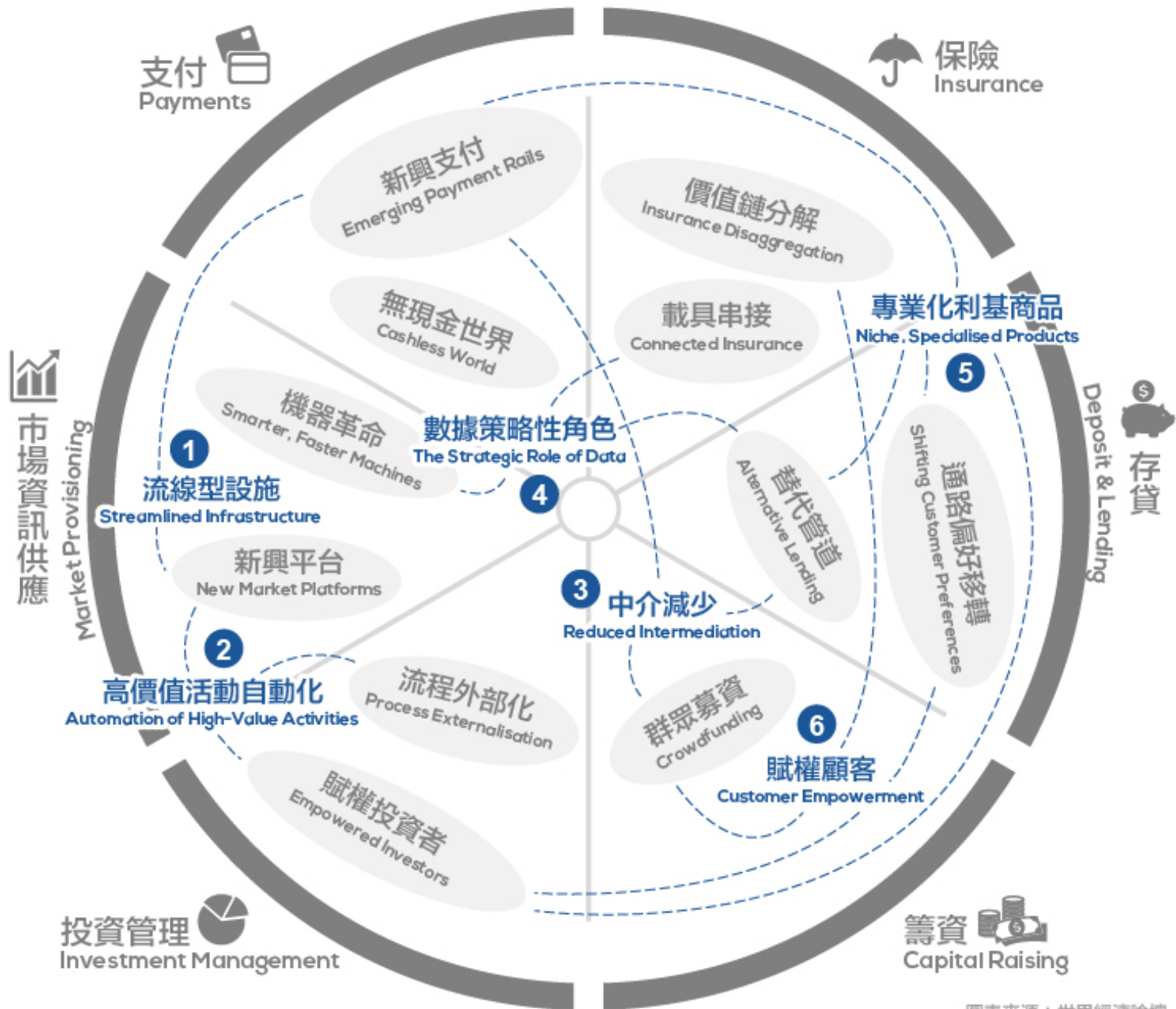

## Financial Services Innovation

1. Payments
2. Insurance
3. Deposits & Lending
4. Capital Raising
- 5. Investment Management**
6. Market Provisioning



圖表來源：世界經濟論壇

# FinTech: Financial Services Innovation

功能	創新項目
 支付 Payments	無現金世界 (Cashless World) 新興支付 (Emerging Payment Rails)
 保險 Insurance	價值鏈裂解 (Insurance Disaggregation) 保險串接裝置 (Connected Insurance)
 存貸 Deposit & Lending	替代管道 (Alternative Lending) 通路偏好移轉 (Shifting Customer Preferences)
 籌資 Capital Raising	群眾募資 (Crowdfunding)
 投資管理 Investment Management	賦權投資者 (Empowered Investors) 流程外部化 (Process Externalisation)
 市場資訊供應 Market Provisioning	機器革命 (Smarter, Faster Machines) 新興平台 (New Market Platforms)

圖表來源：Fugle團隊整理

# 5 FinTech: Investment Management

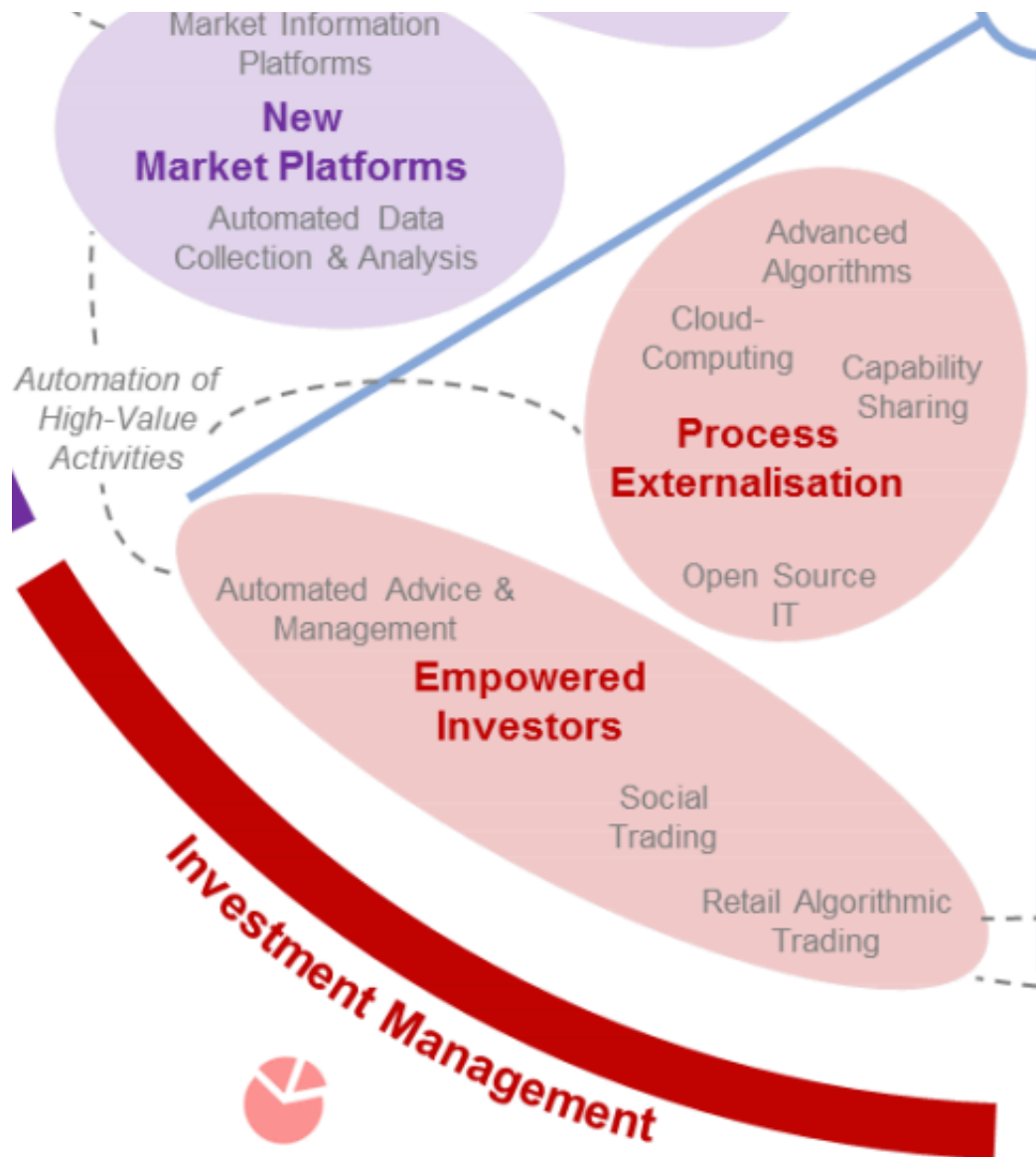



# 5 FinTech: Investment Management Empowered Investors Process Externalization

投資管理



創新

關鍵趨勢

<b>賦權投資者</b> Empowered Investors	社群交易、機器推薦與財富管理、零售演算法交易 (Retail Algorithmic Trading)
<b>流程外部化</b> Process Externalisation	流程即服務 (Process-as-a-Service, PaaS)、能力共享 (Capability Sharing)、進階分析、自然語言

圖表來源：Fugle團隊整理



# 6

# FinTech: Market Provisioning

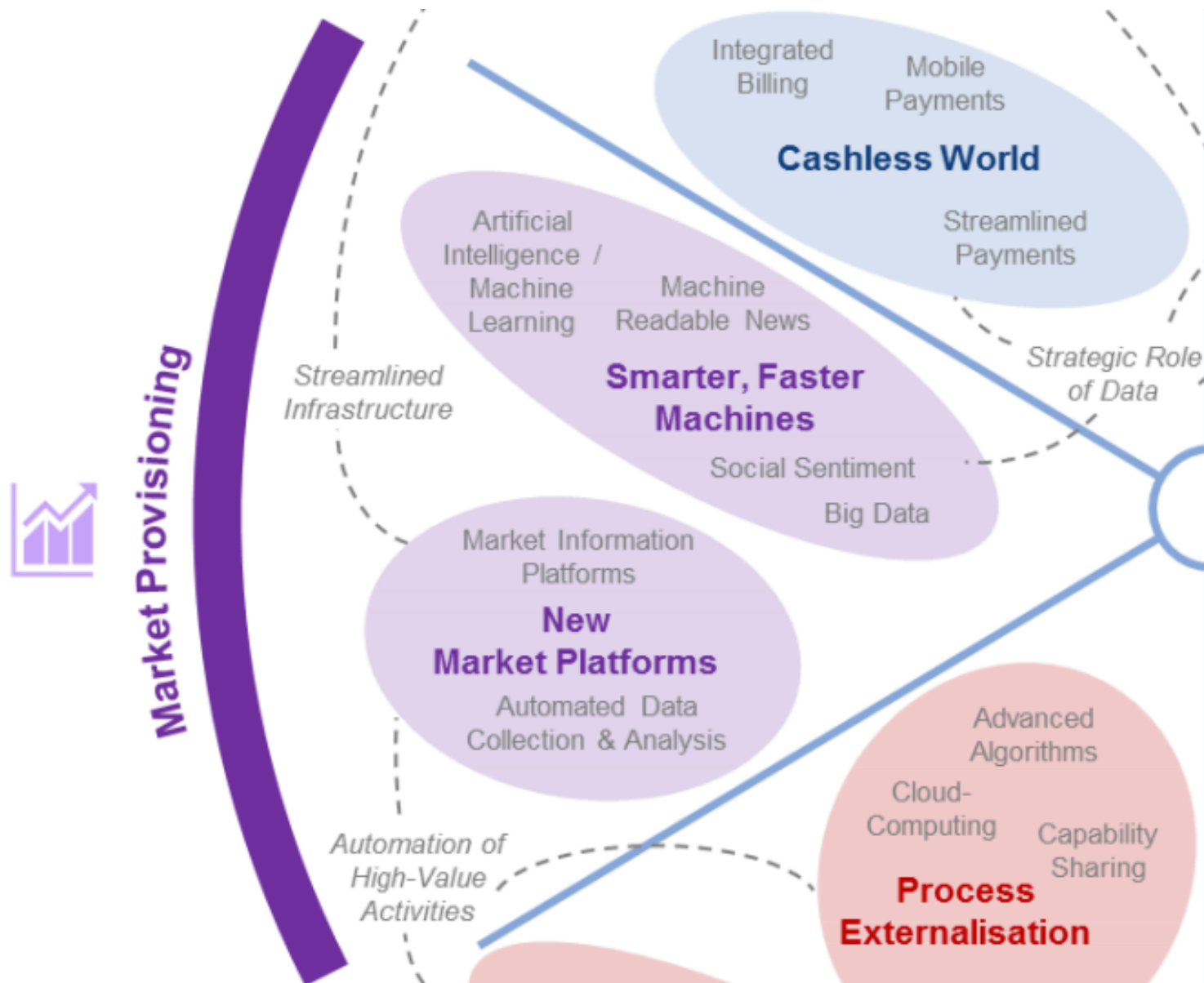

# 6

## FinTech: Market Provisioning Smarter, Faster Machines New Market Platforms

市場資訊供應



創新

關鍵趨勢

**機器革命**  
Smarter, Faster  
Machines

機器易用數據 (Machine Accessible Data)、人工智慧 / 機器學習、大數據

**新興平台**  
New Market  
Platforms

固定收益商品平台 ALGOMI、基金 / 組合型基金平台 NOVUS、私募 / 創投平台 BISON、未公發股權平台 LIQUITY、原物料商品與衍生性合約平台 ClauseMatch

圖表來源：Fugle團隊整理

# AI and Big Data Analytics in Finance

- 財務金融大數據分析
  - Big Data Analytics in Finance
- 投資大數據分析
  - Big Data Analytics in Investment
- 人工智慧與財務應用
  - Artificial Intelligence and Financial Application
- 人工智慧與投資分析
  - Artificial Intelligence and Investment Analysis

# Question Answering

# Dialogue System

# Chatbot

**From  
E-Commerce  
to  
Conversational Commerce:  
Chatbots  
and  
Virtual Assistants**

# H&M's chatbot on Kik

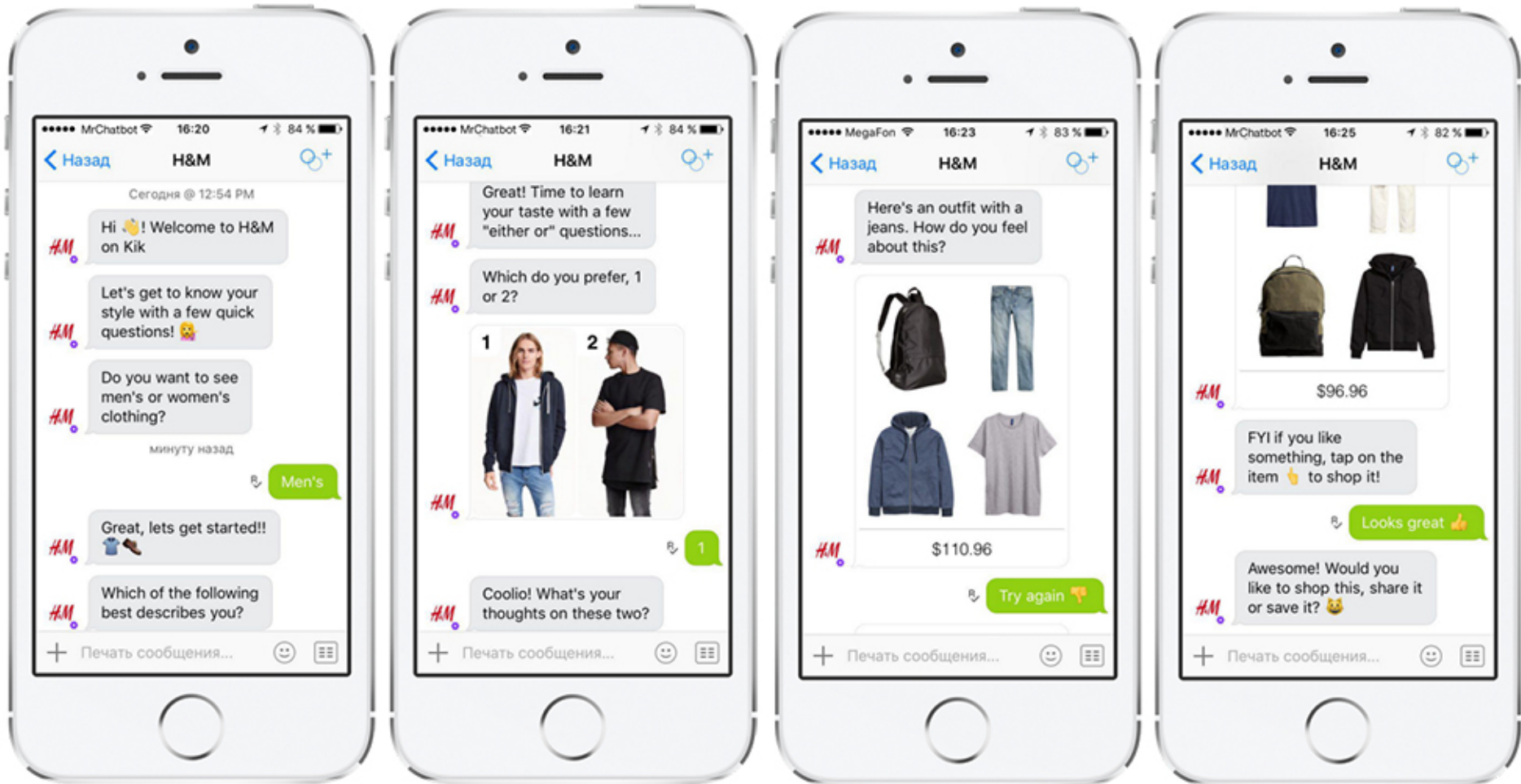



# Uber's chatbot on Facebook's messenger

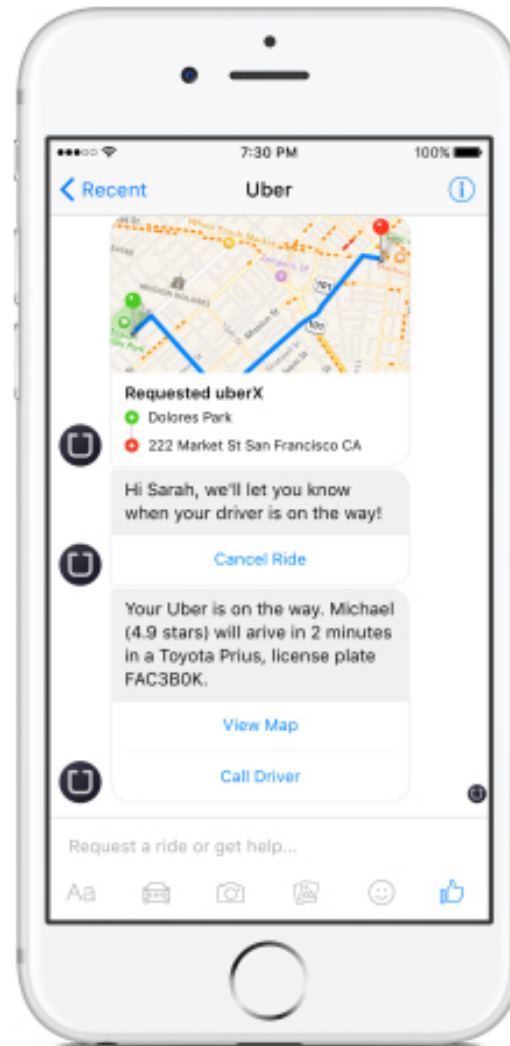

Uber's chatbot on Facebook's messenger  
- one main benefit: it loads much faster than the Uber app

Source: <http://www.guided-selling.org/from-e-commerce-to-conversational-commerce/>

# Savings Bot

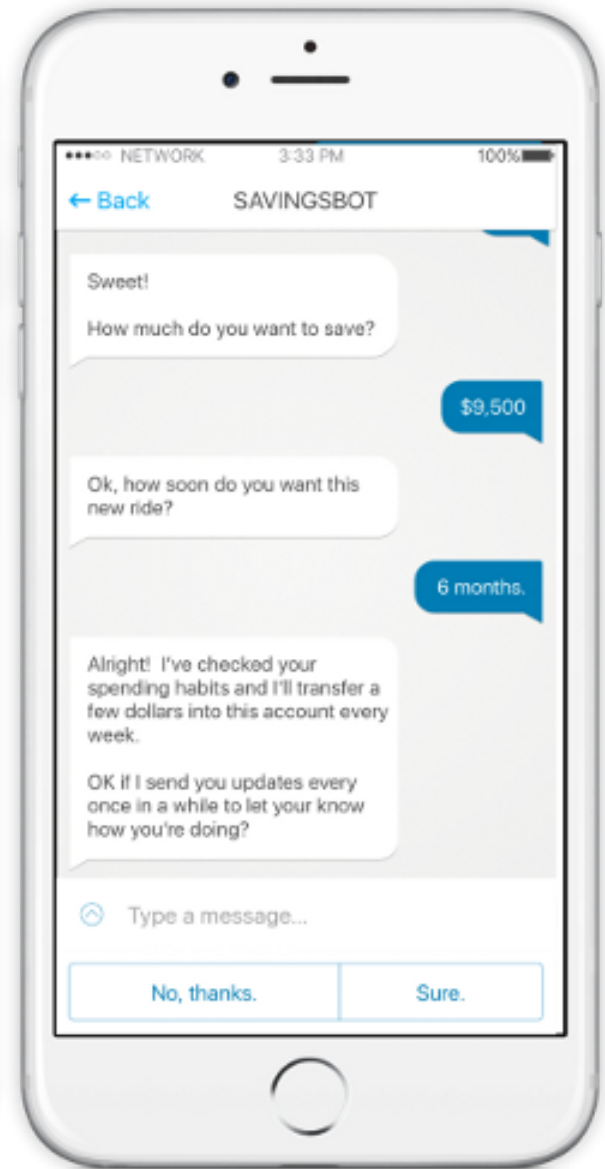
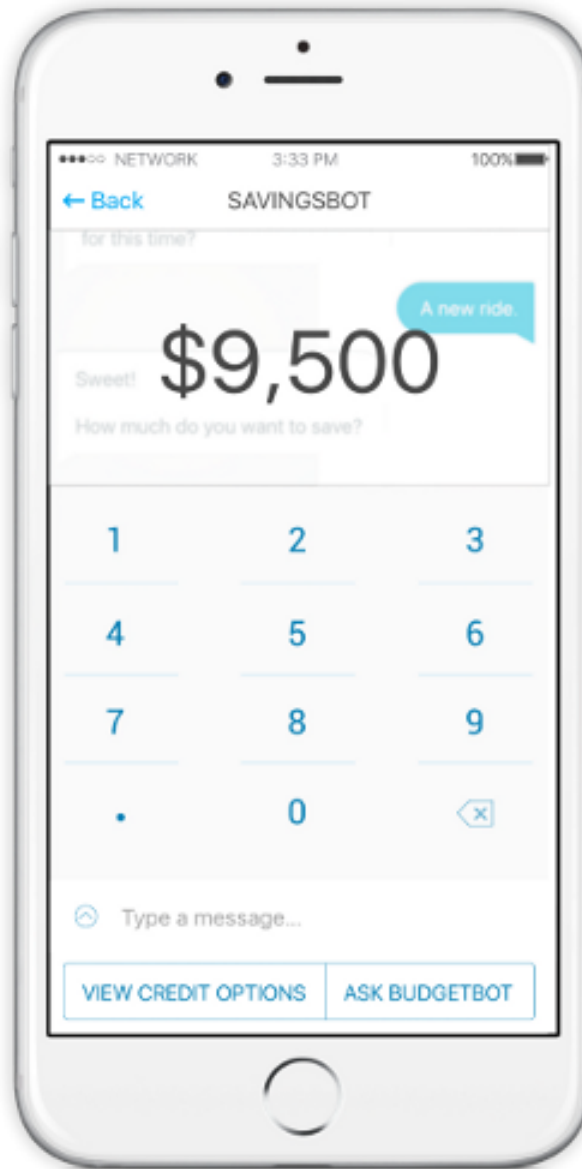
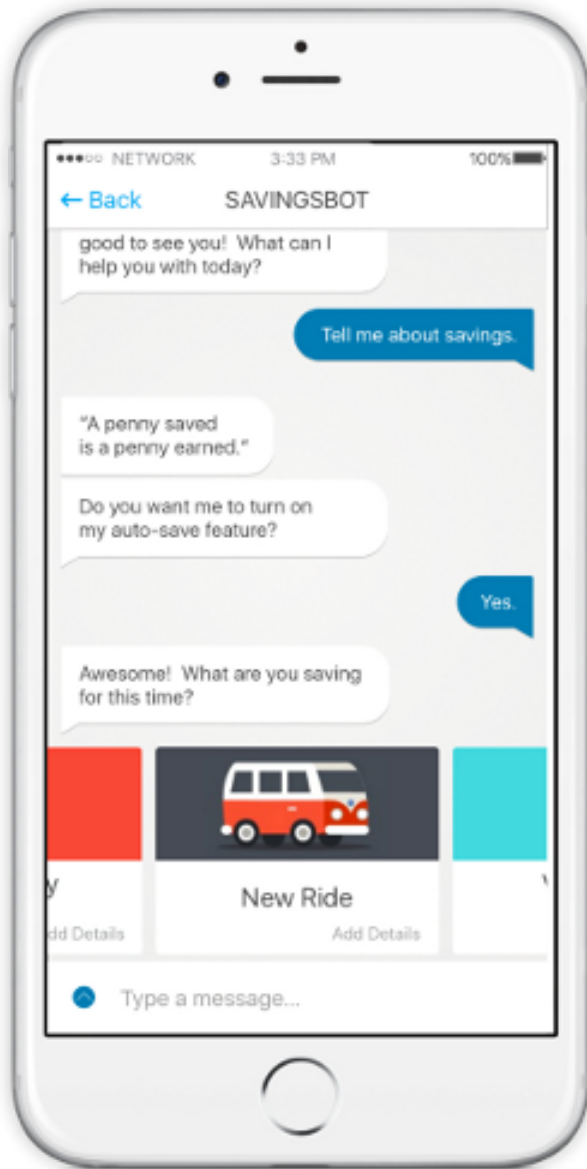

# The bot platform ecosystem and the emerging giants

Nearly every large software company has announced some sort of bot strategy in the last year. Here's a look at a handful of leading platforms that developers might use to send messages, interpret natural language, and deploy bots, with the emerging bot-ecosystem giants highlighted.

## General AI agents with platforms

Developer access available now or announced

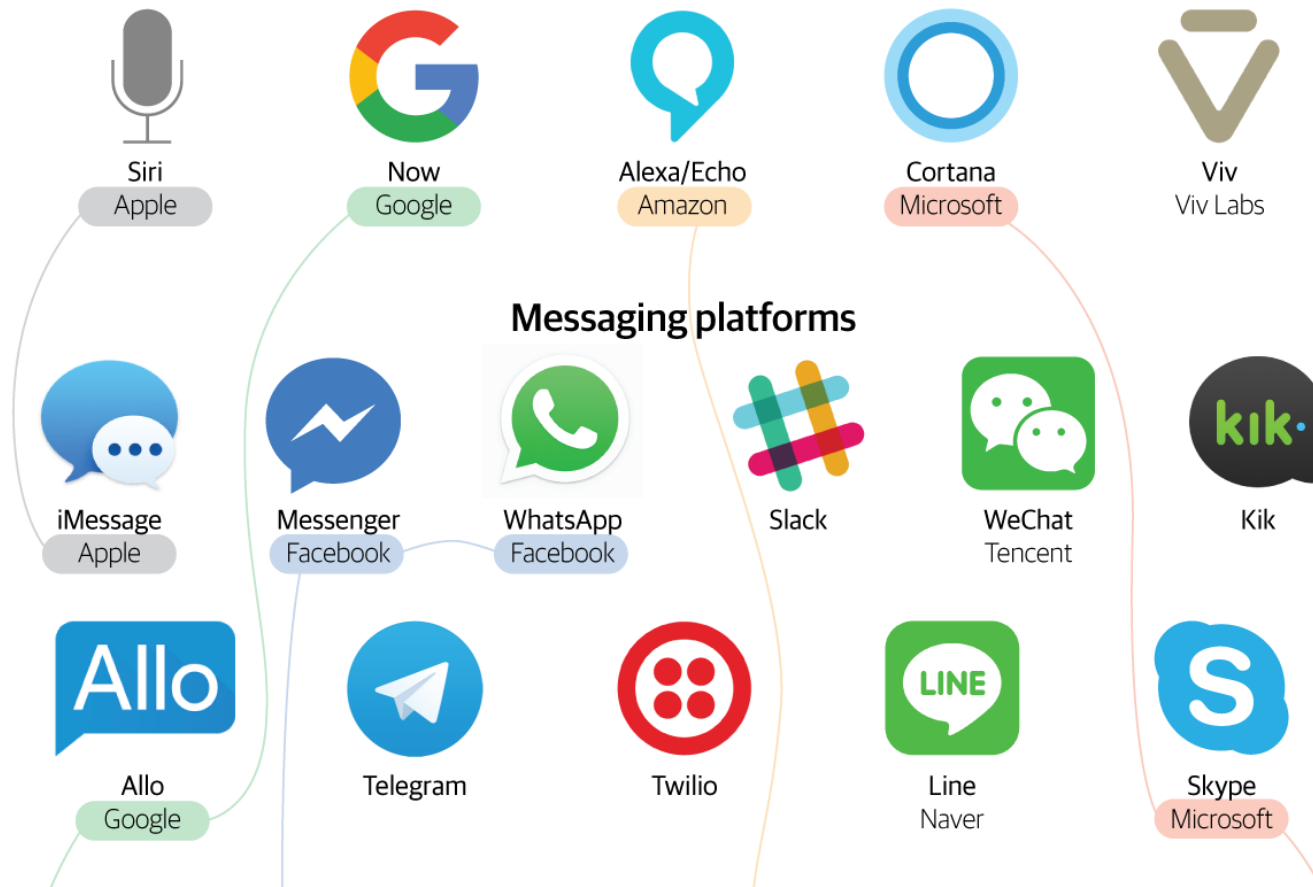

## Bot frameworks and deployment platforms

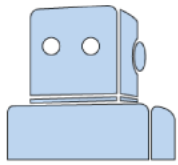

Wit.ai  
Facebook



BotKit  
Howdy



Chatfuel

AUTOMAT

Automat



Bot Framework  
Microsoft



Api.ai  
Google



Pandorabots



MindMeld



Gupshup



Sequel

## Bots with traction

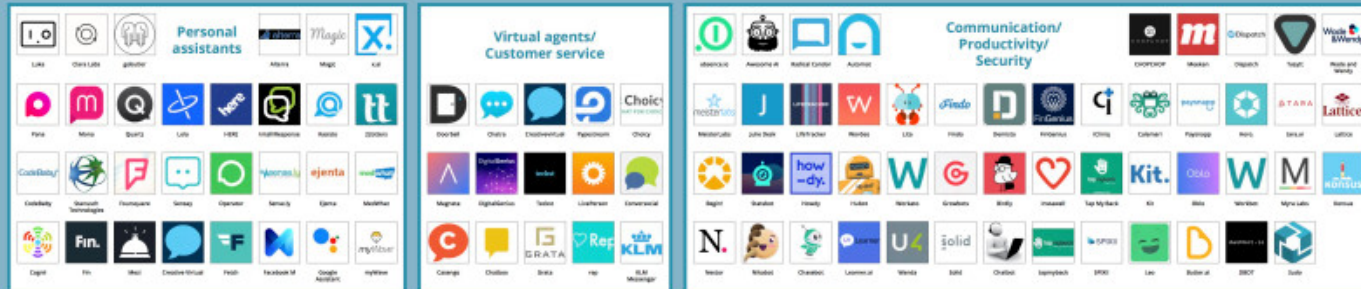

## Connectors/ Shared Services



## AI Tools: Natural Language Processing, Machine Learning, Speech & Voice Recognition

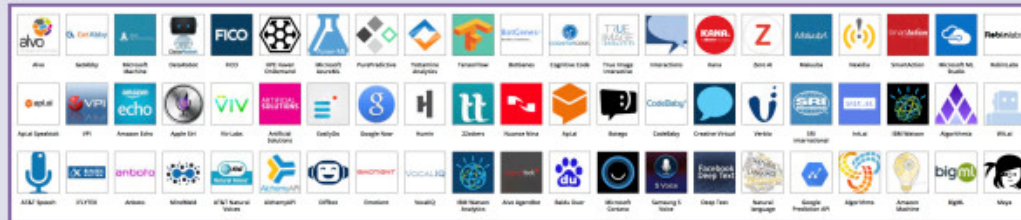

## Bot Discovery

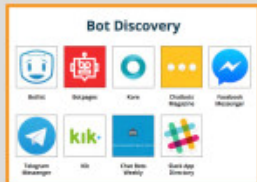

## Bot developer frameworks and tools

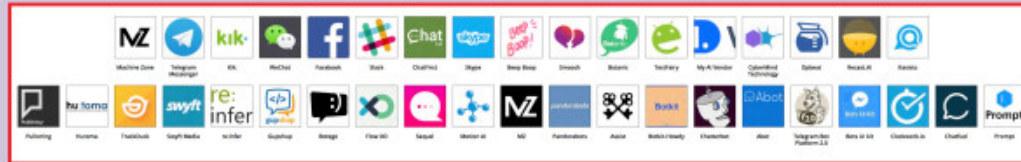

## Analytics

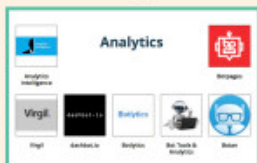

## Messaging

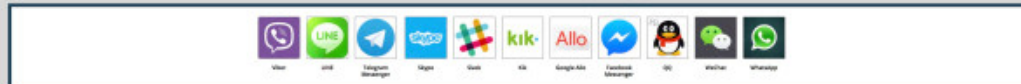

## Food

The Wine Pairer Plum Pescetarian Kitchen Hungry Foodie

Fitmeal Entrée Chatobook Make My Sushi Voome

## Communication

Tangowork Typeform Anony Tajimly Refugio Rescue Messenger Match

Sensay LangLearnBot Chat Club Lingio Translate Decodemoji U-Report Global Twiggo

## Utilities

Poncho Calcbot Smokey DotCom Server Monitoring

English Dictionary Youtube Search Idea Bot QRbot Instant Translator

## Personal

M Assist Operator Uber Swelly AskVoila

Ikea Build Selectionnist Bud Light Bot Ask Gary Vee Gidi Visabot

## Analytics

SISENSE Stockflare Pagesights DAM BuzzLogger Trading Bot

## Travel

Grindbase KLM British Airways Space Explorer Austrian Airlines

SnapTravel Skyscanner Kayak Ticketbot Rapido

## Entertainment

Spotify Kim Kardashian La Bringue 50 Cent Loquillo Fiel Lindsay Lohan Maroon 5

MTV News Axwell A Ingresso RedBull TV SantaBot Star Wars Bot Citron Pokébot

## Design

ColoretoBot Connie Digital AWWWARDS Mr. Norman Graphic Design SnapBot

## News

CNN TIA Digg WSJ Reddit Bot Al Jazeera

Hacker News Wired The Guardian France Info Chatbots Mag VentureBeat

## Developer Tools

HackerOne Wiredelta

Robbie Zilly

## Education

Genius Kimchi

MemoryzerBot Einstein



# System Architecture of Intelligent Dialogue and Question Answering System

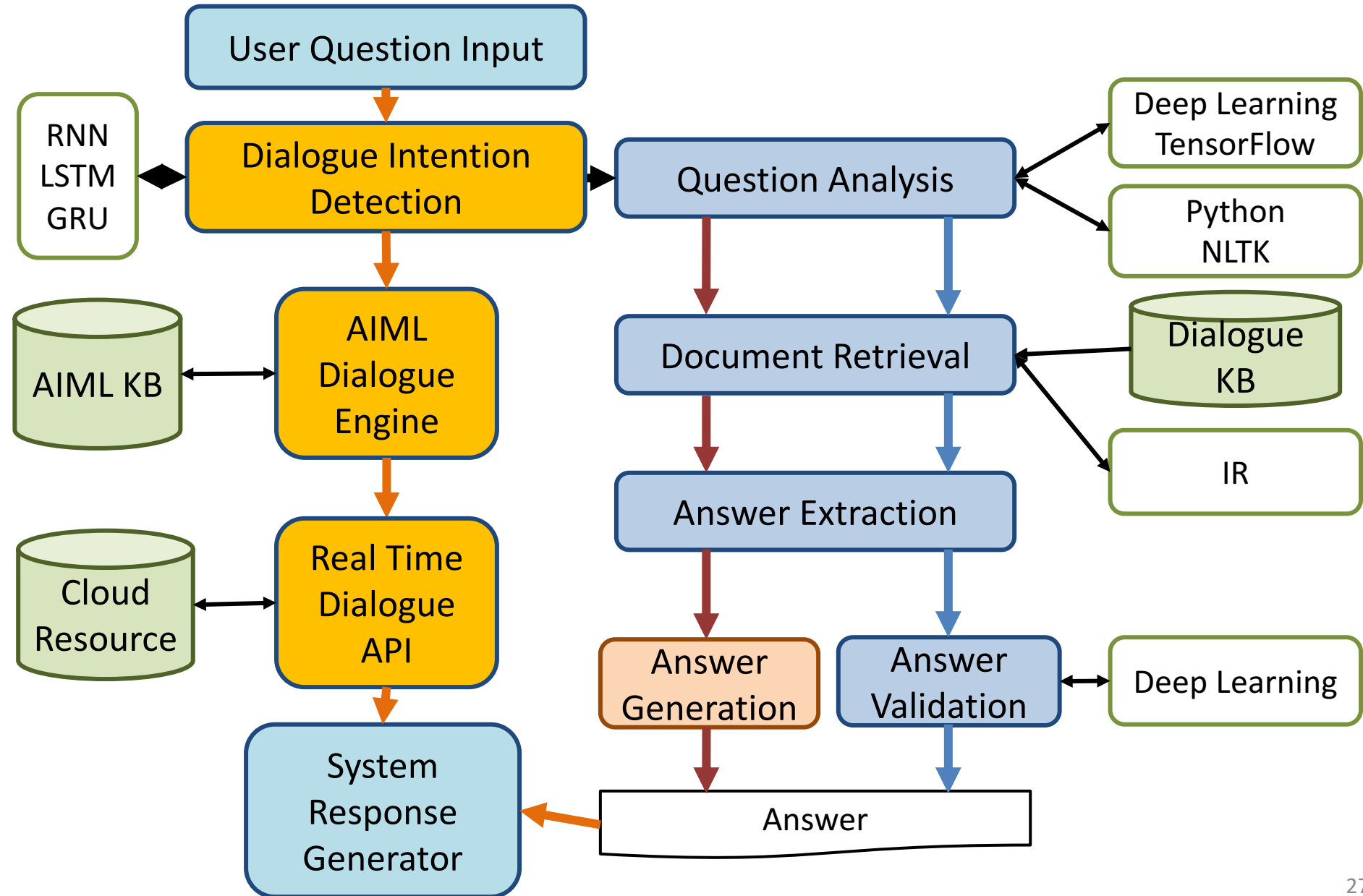



# IMTKU System Architecture for NTCIR-12 QALab2

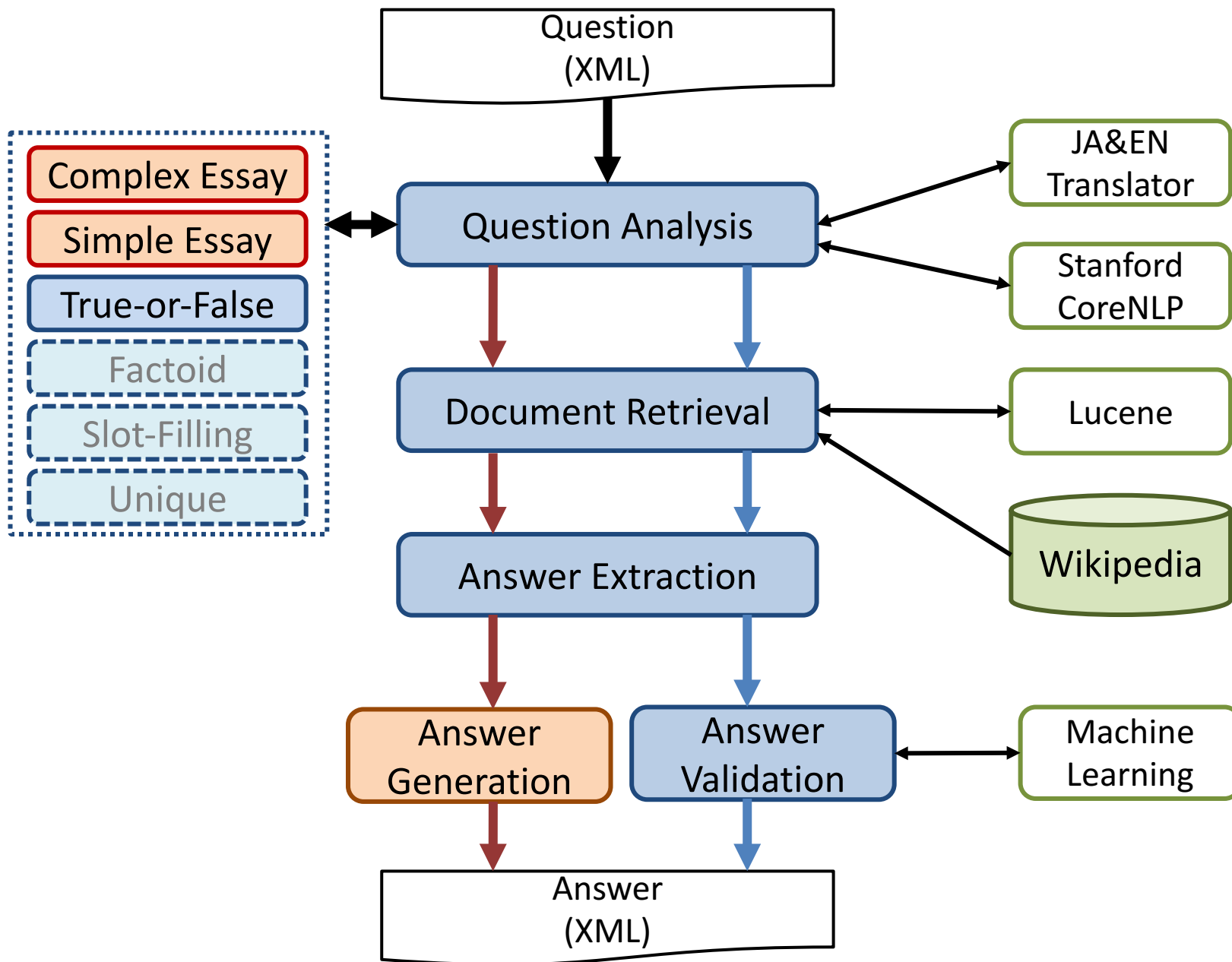



# Dialogue System

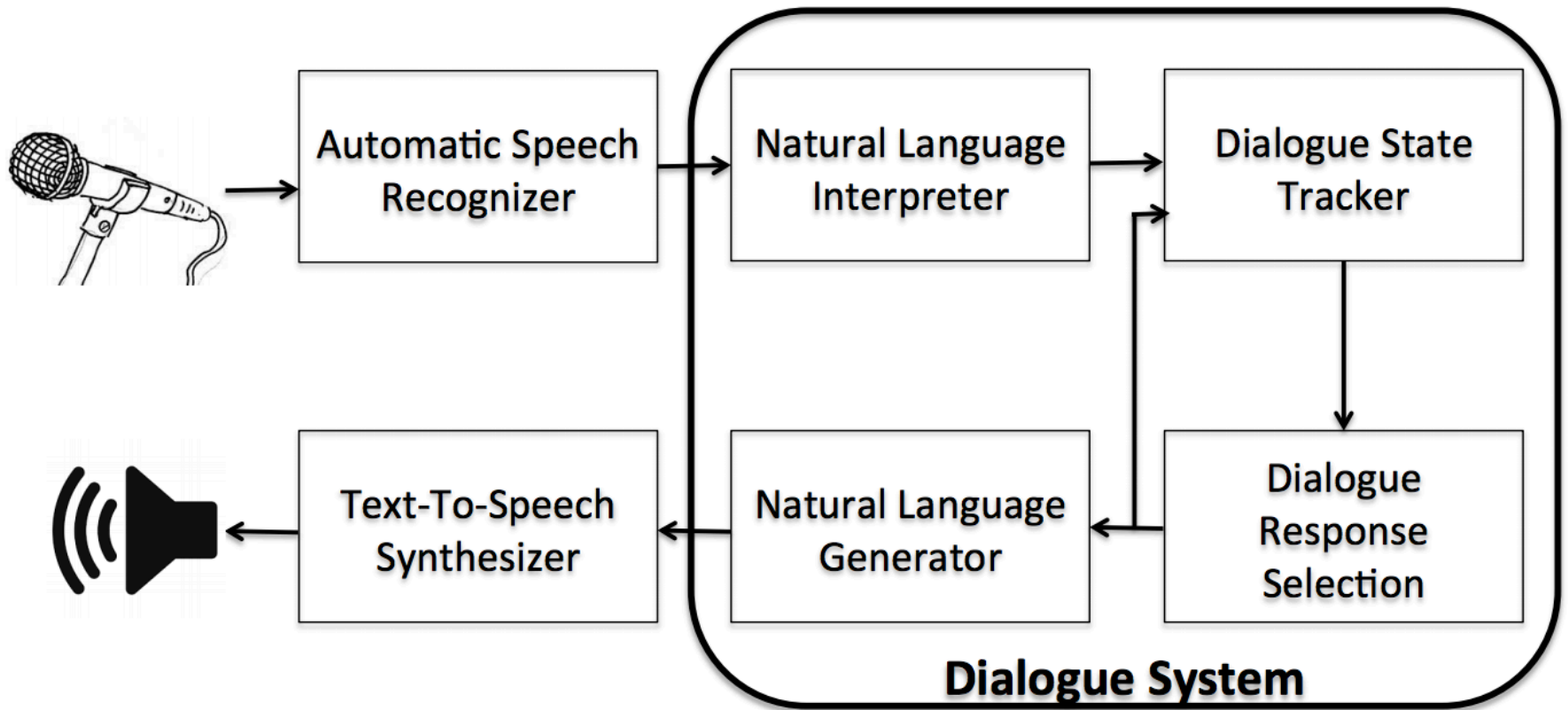

# Chat-oriented Dialogue System

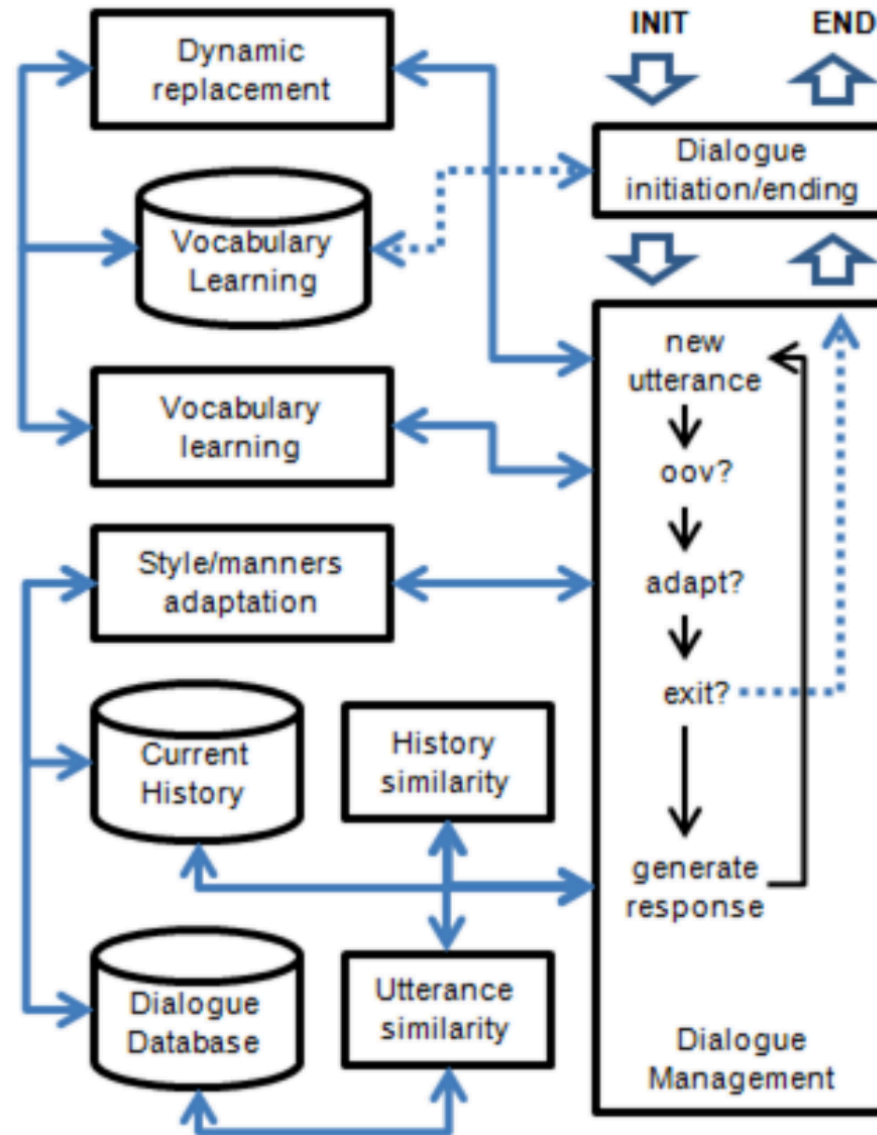

# AIML Dialogue System

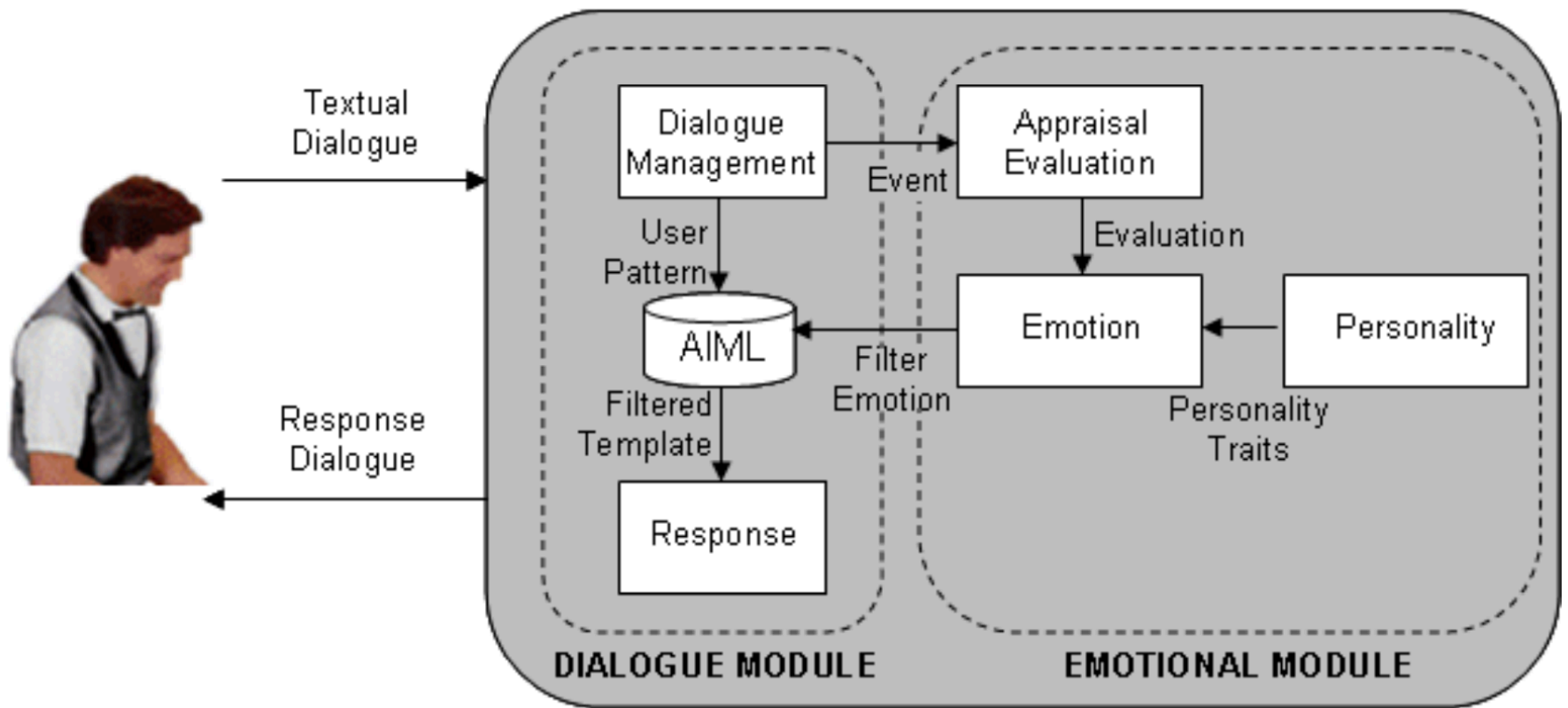

# Deep Learning for Dialogues

## Intent Classification

## Intent LSTM

**LSTM (Long-Short Term Memory)**

**GRU (Gated Recurrent Unit)**

# Dialogue Utterance

<b>W</b>	find	recent	comedies	by	james	cameron
	↓	↓	↓	↓	↓	↓
<b>S</b>	O	B-date	B-genre	O	B-dir	I-dir
<b>D</b>	movies					
<b>I</b>	find_movie					

An example utterance with annotations of semantic slots in IOB format (S), domain (D), and intent (I), B-dir and I-dir denote the director name.

# End-to-end Memory Network Model for Multi-turn SLU

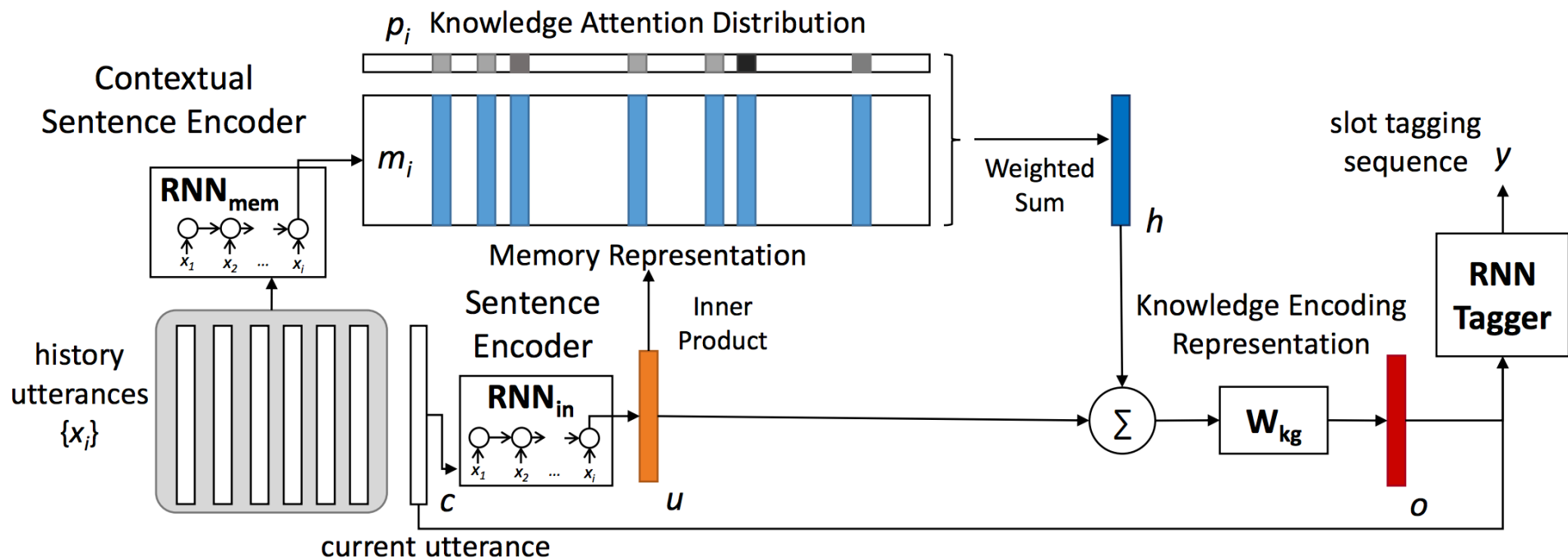



# Deep Learning for SLU

## (Spoken Language Understanding)

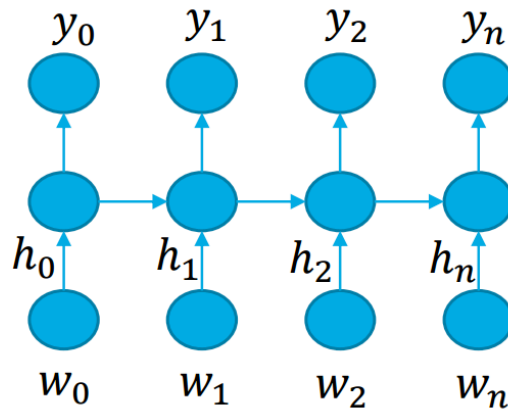

(a) LSTM

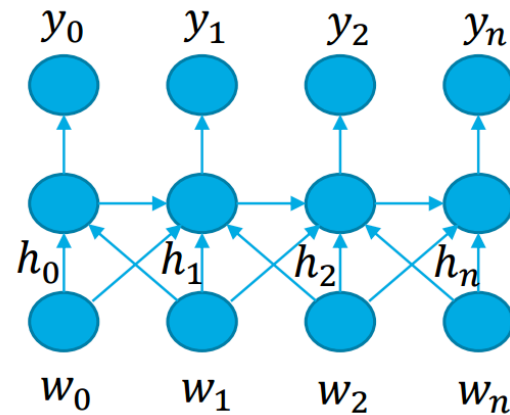

(b) LSTM-LA

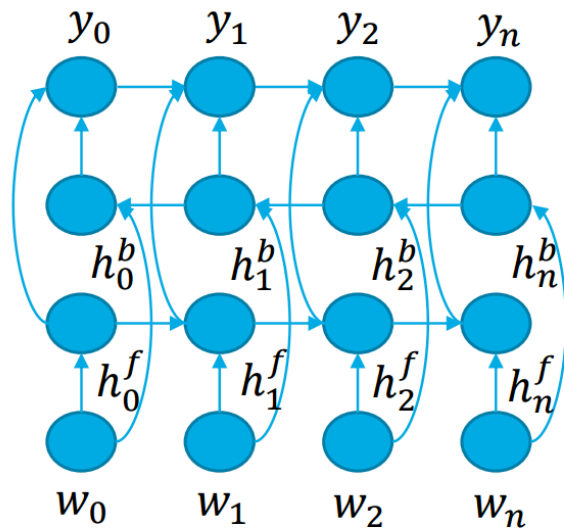

(c) bLSTM-LA

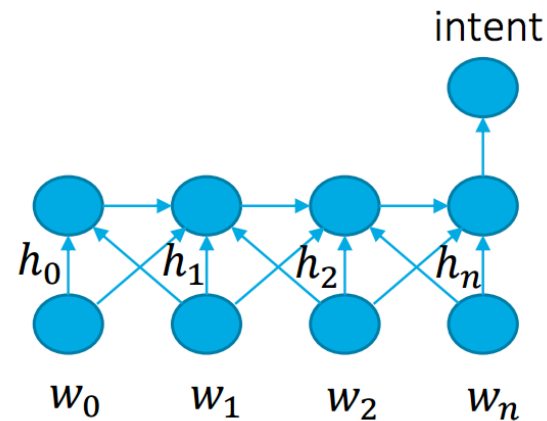

(b) Intent LSTM



# Encoder-decoder model for joint intent detection and slot filling

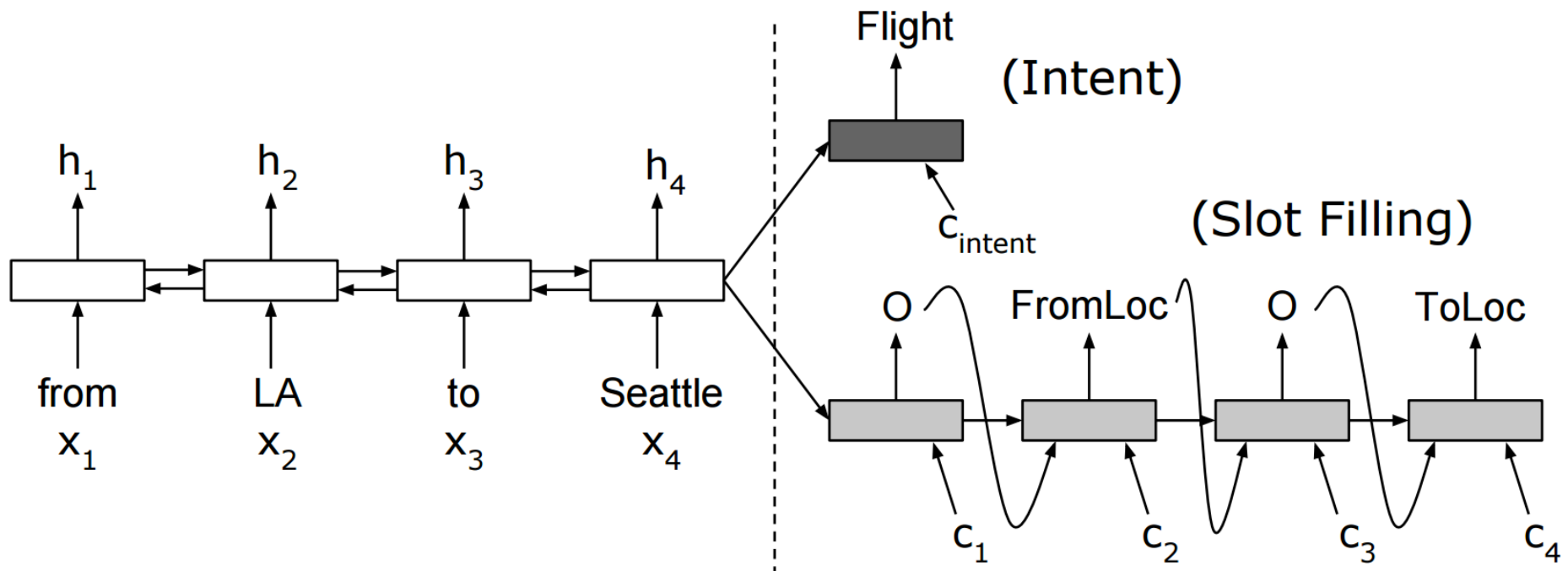

(a) with no aligned inputs.

# Encoder-decoder model for joint intent detection and slot filling

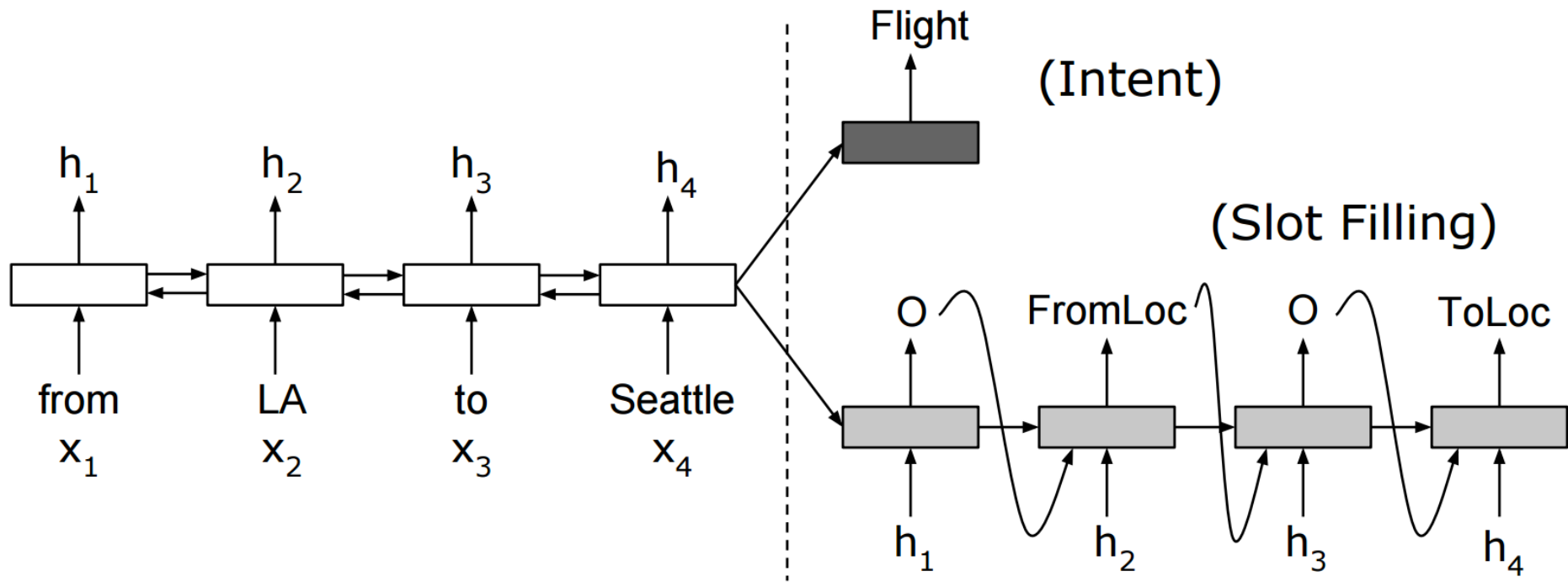

(b) with aligned inputs.

# Encoder-decoder model for joint intent detection and slot filling

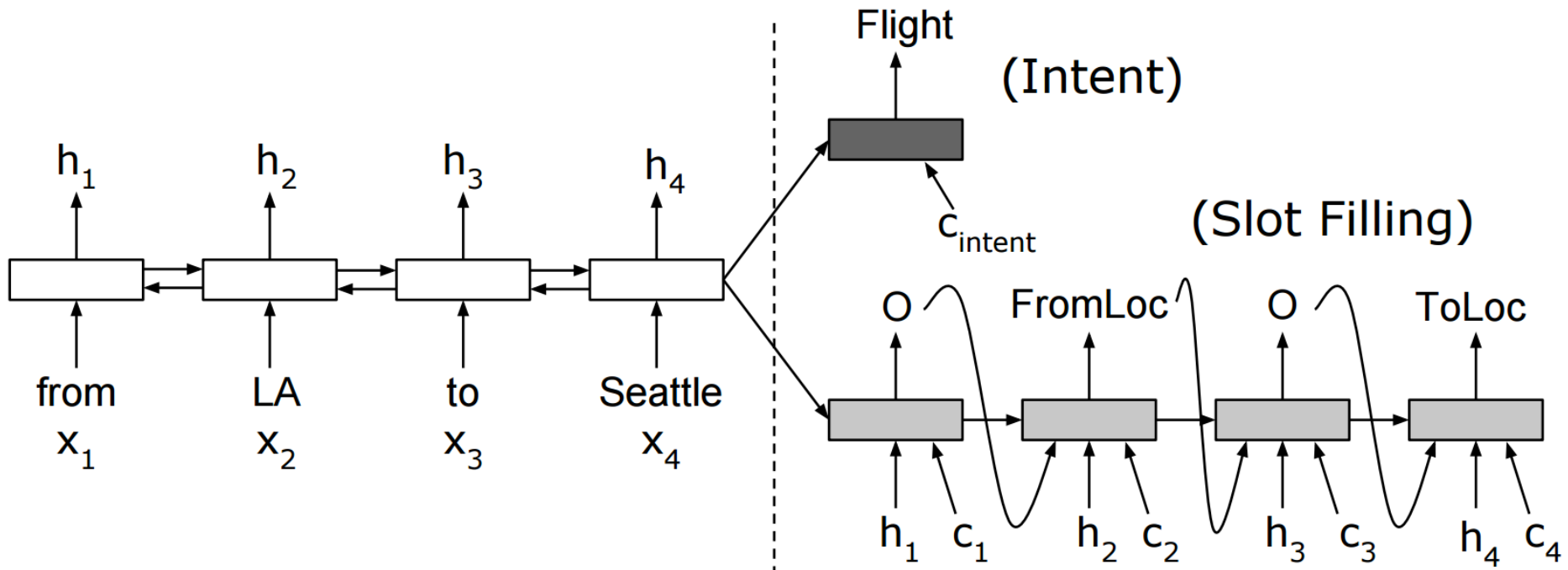

(c) with aligned inputs and attention

# LSTM/GRU Utterance Classifier

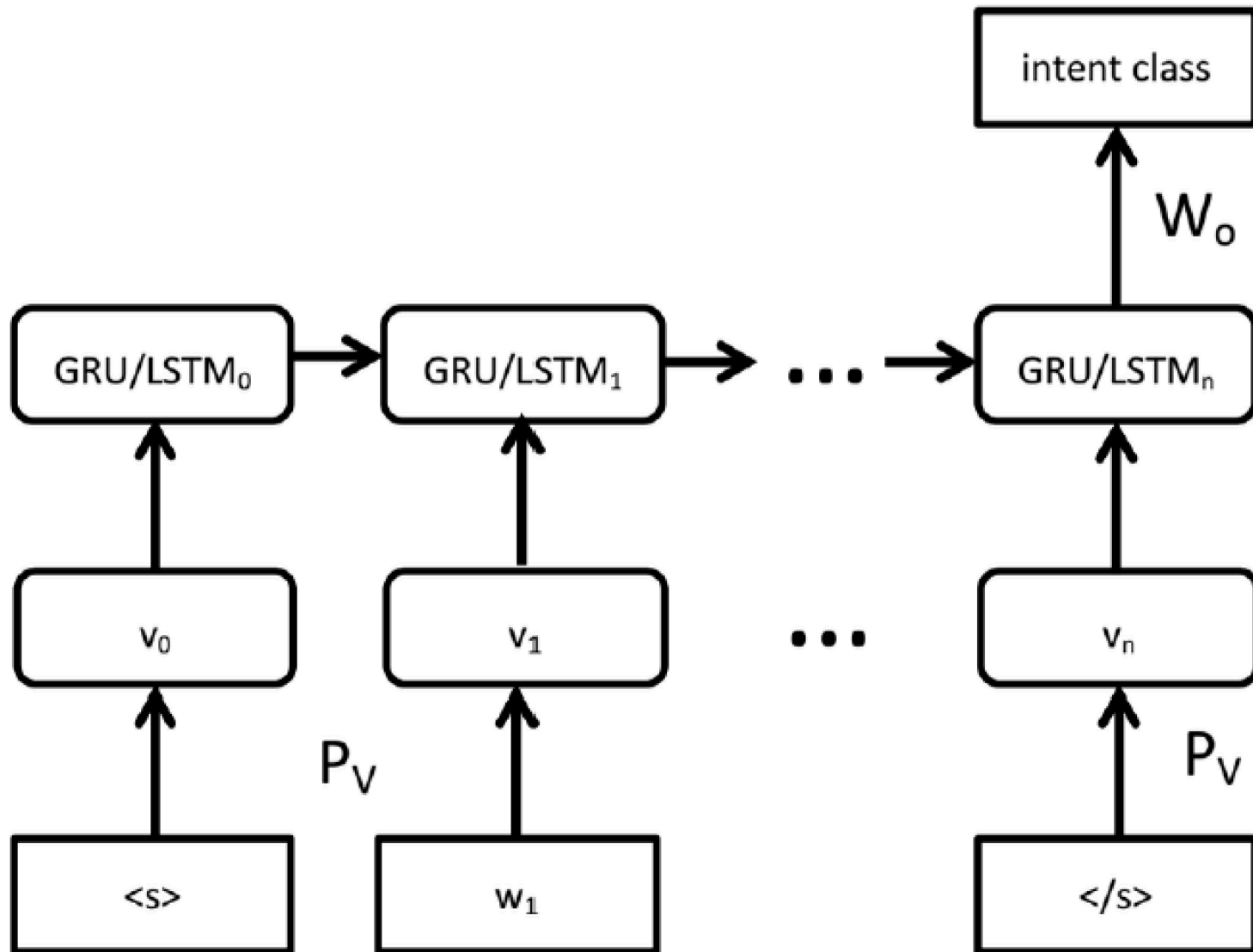

# RNN and LSTM cell

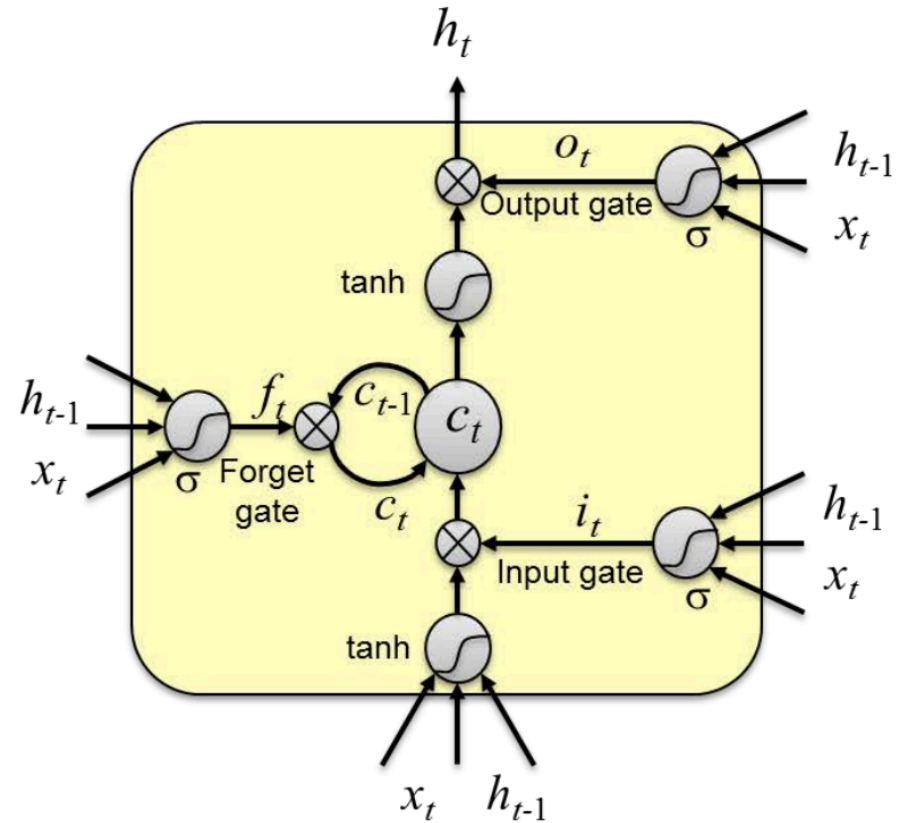
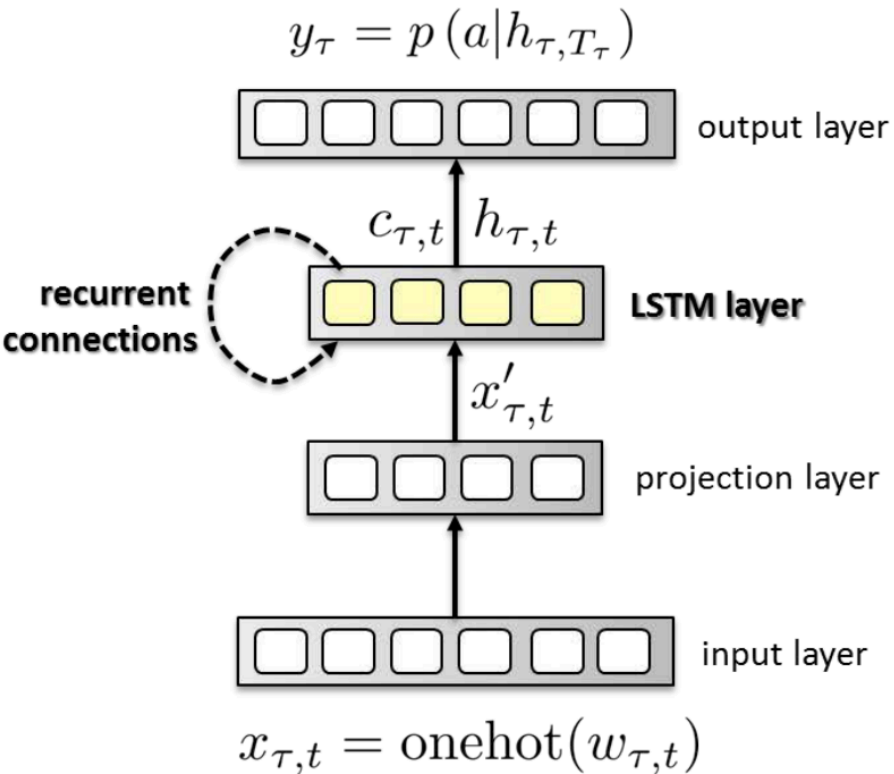

# Basic Chat Bot Components

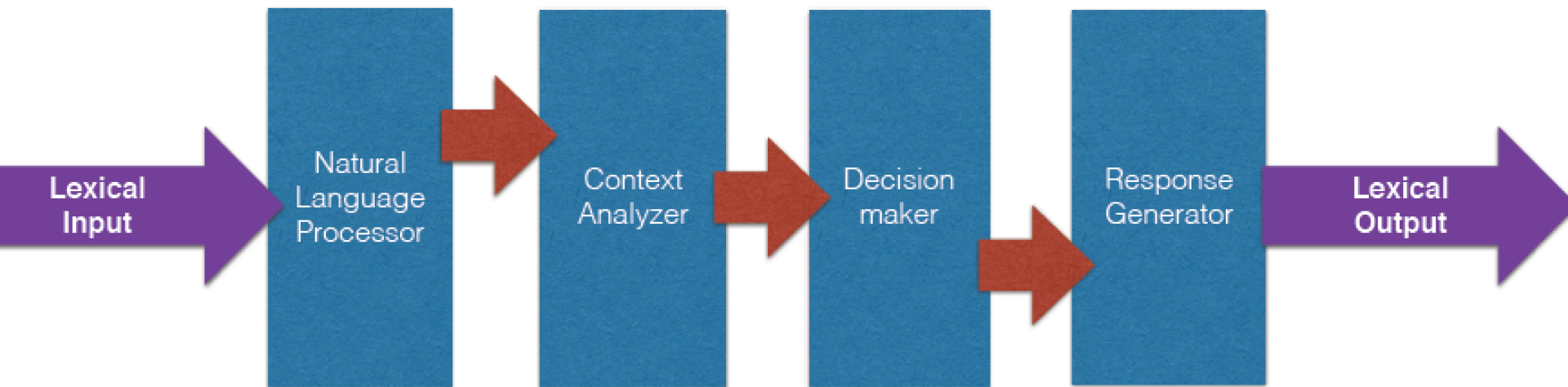

# Traditional Chat Bots

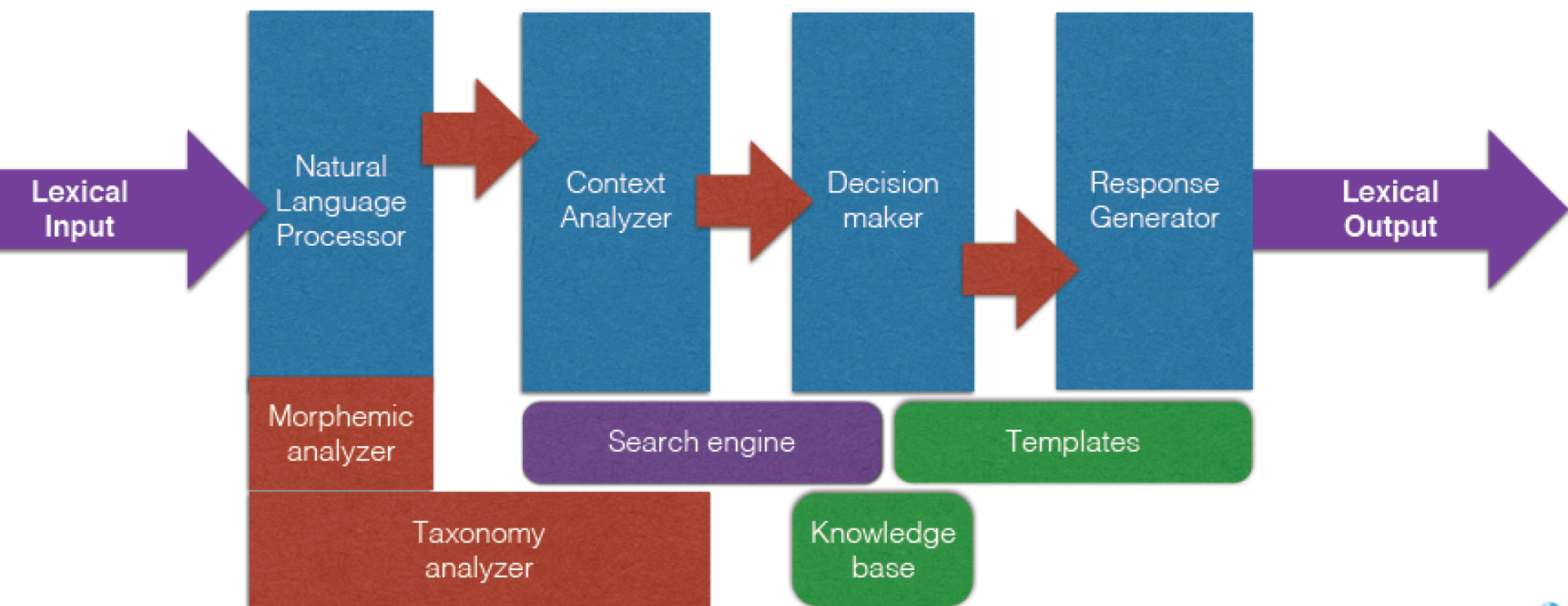

# Chatbots with Machine Learning

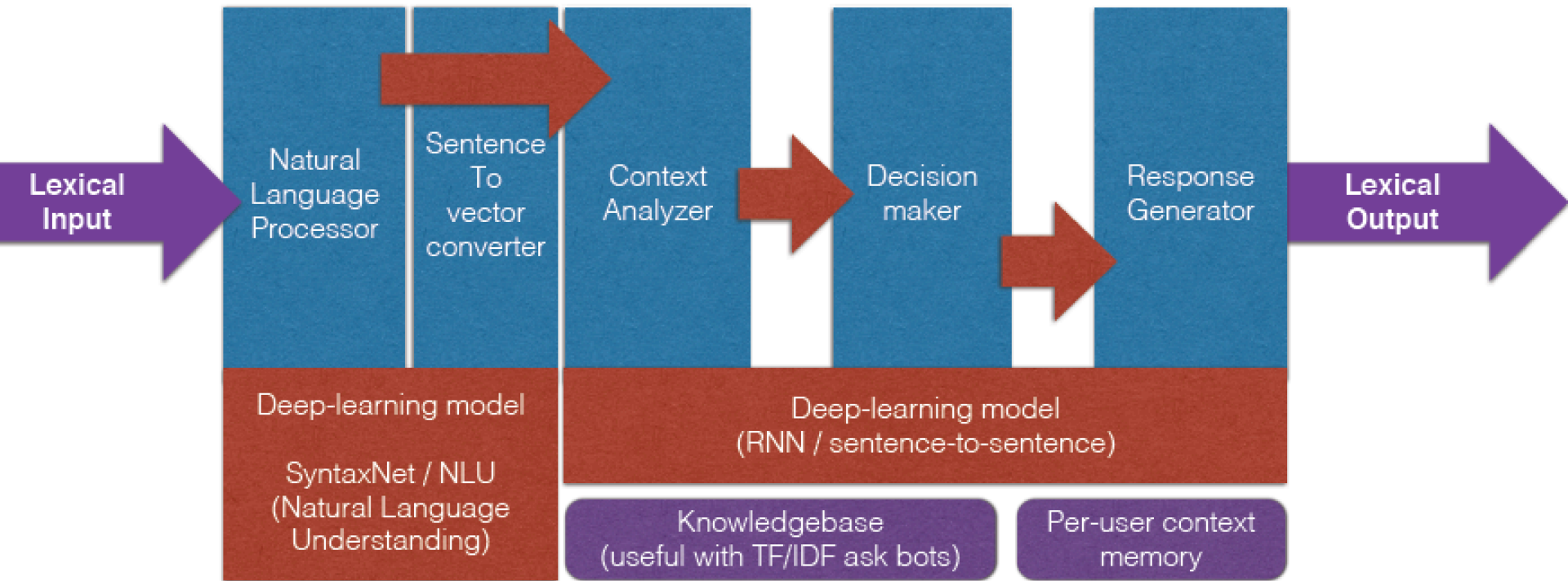



# How Brain Works

- Parallelism: performing a task at separated areas

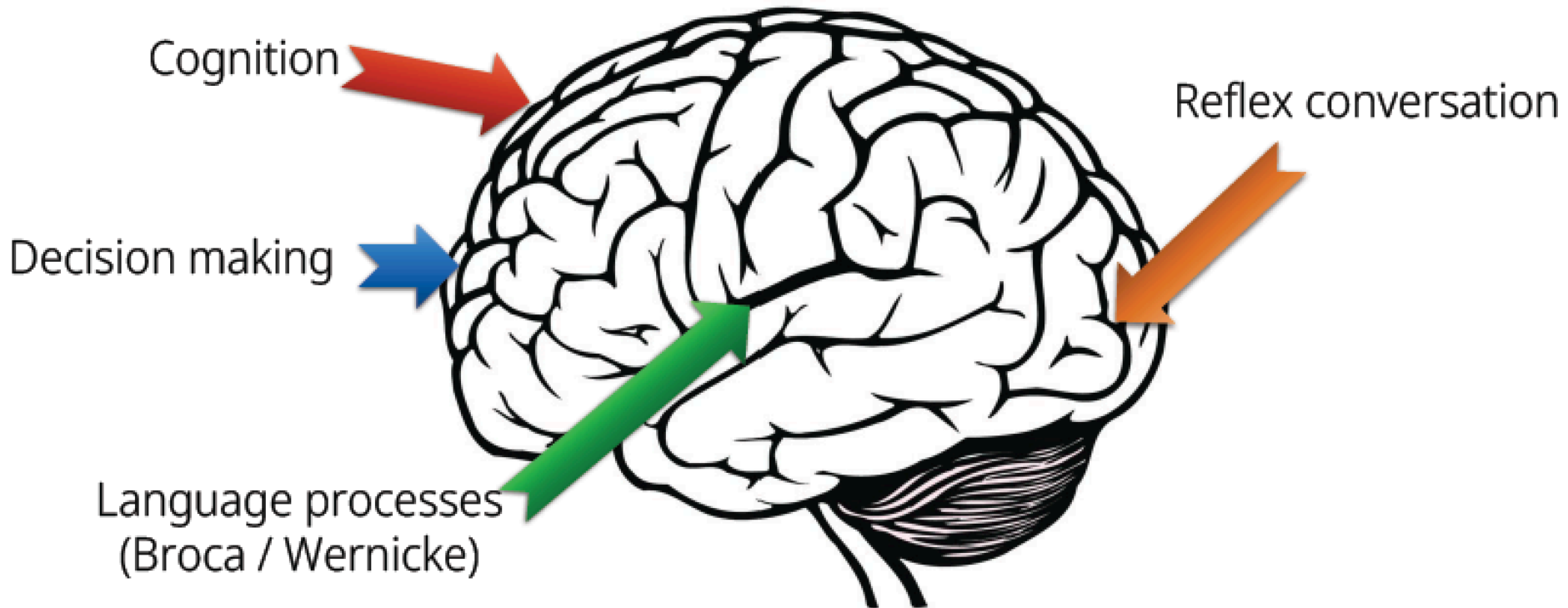

# Information Pathway During Conversation

- During conversation:

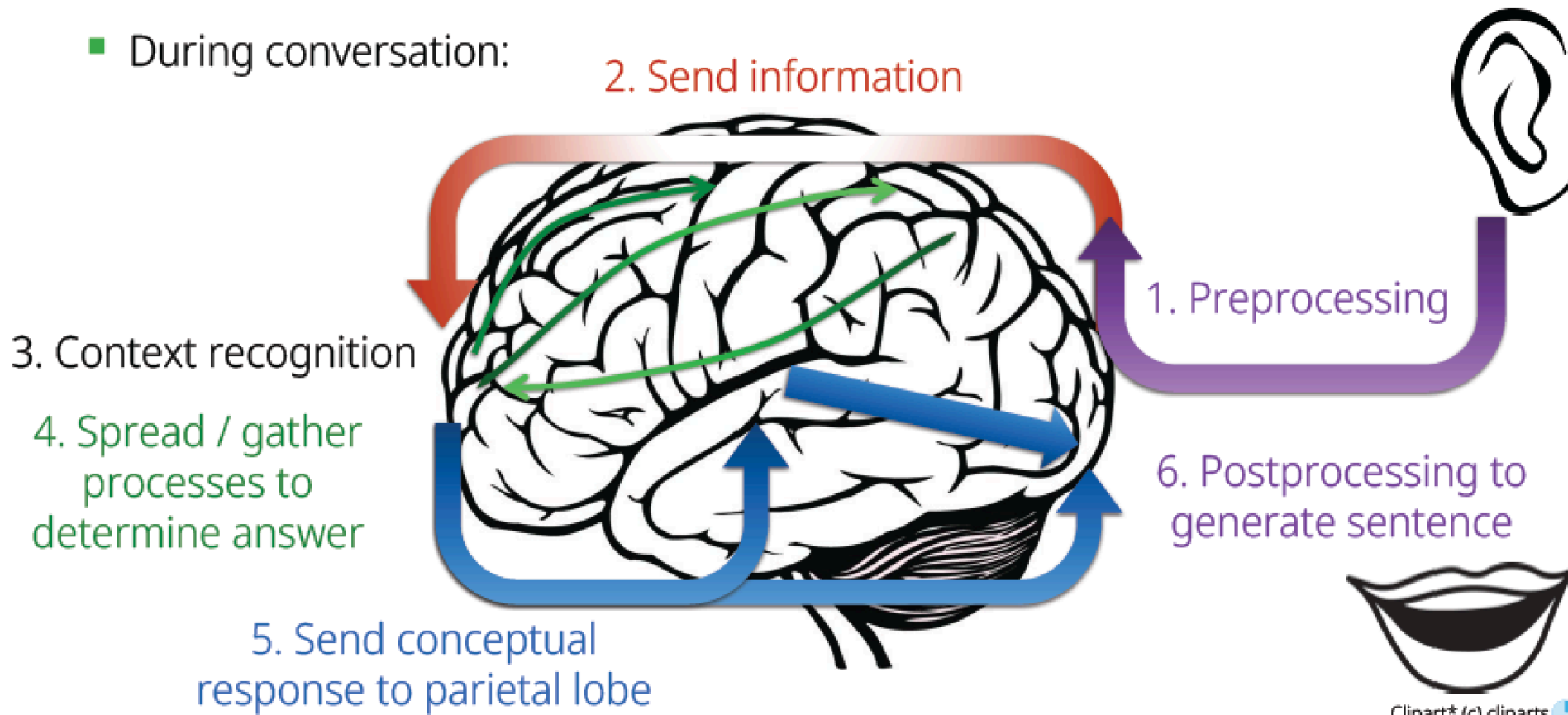

Clipart\* (c) cliparts.

# Idea from Structure

- During conversation:

2. Send information

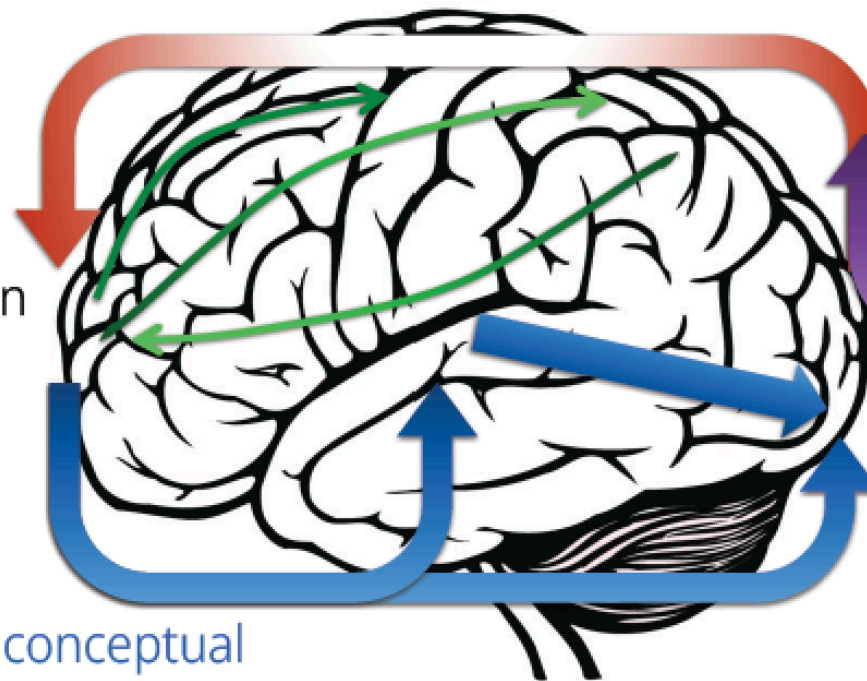

1. Preprocessing

3. Context recognition

4. Spread / gather processes to determine answer

5. Send conceptual response to parietal lobe

6. Postprocessing to generate sentence



Clipart\* (c) cliparts.

# AI Deep Learning Chatbot Architecture

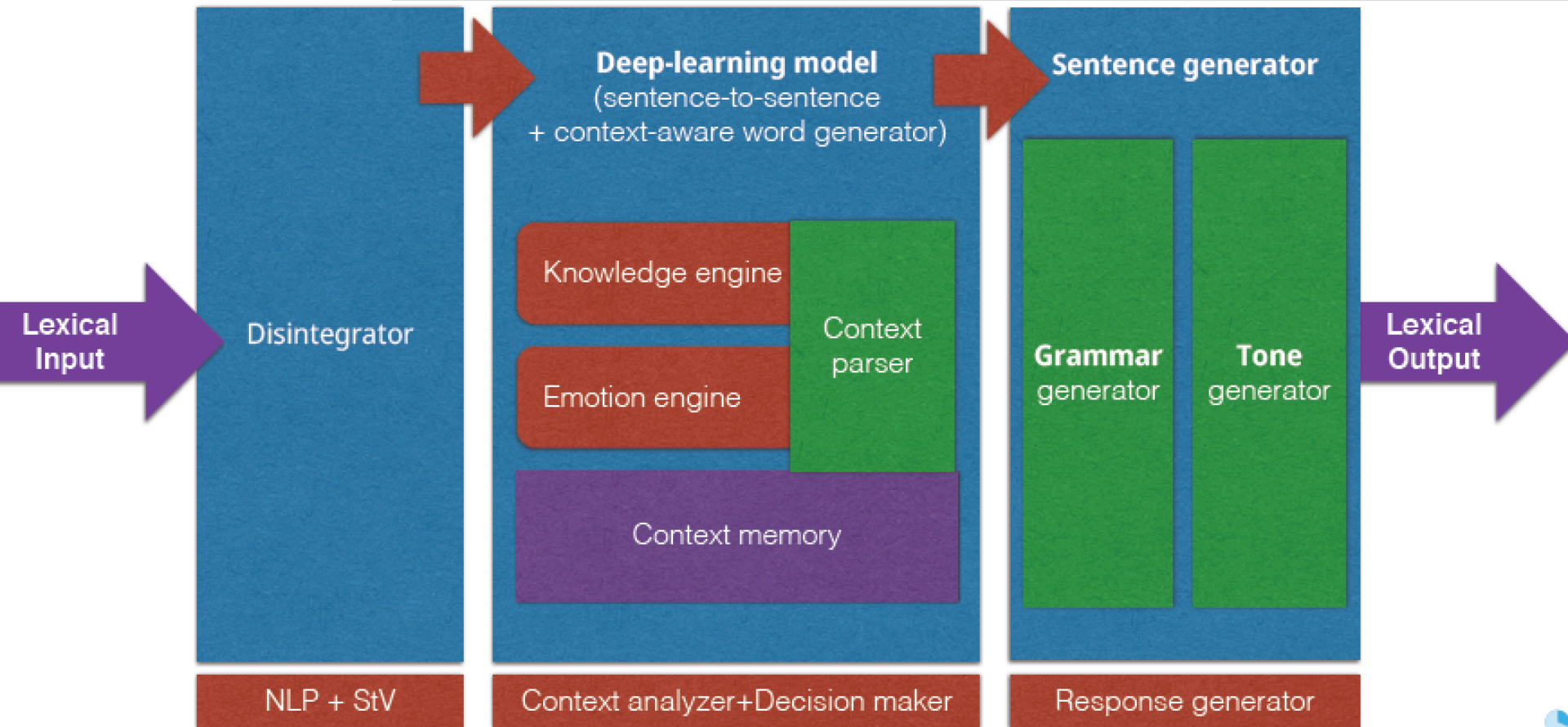

# Model Chain Order

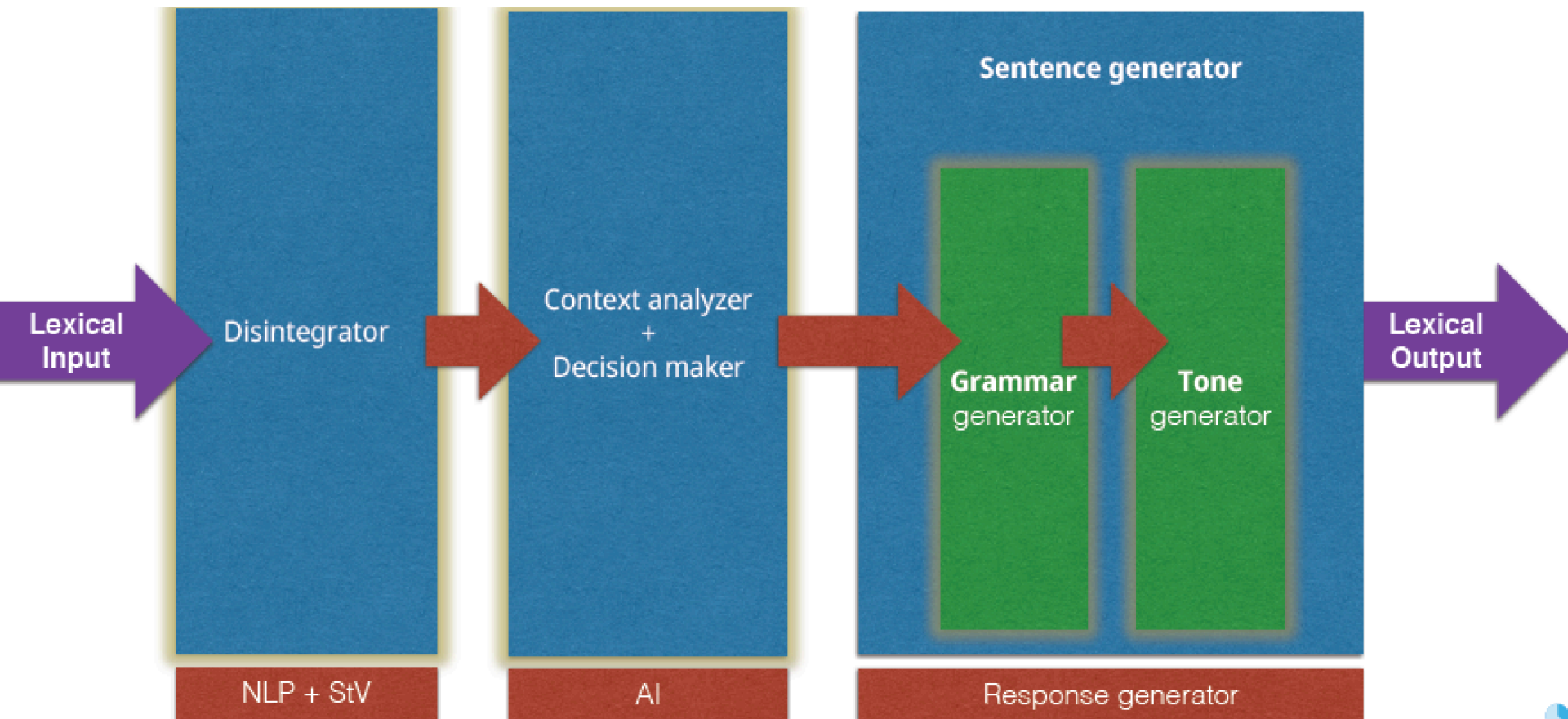



# Model Chain Order

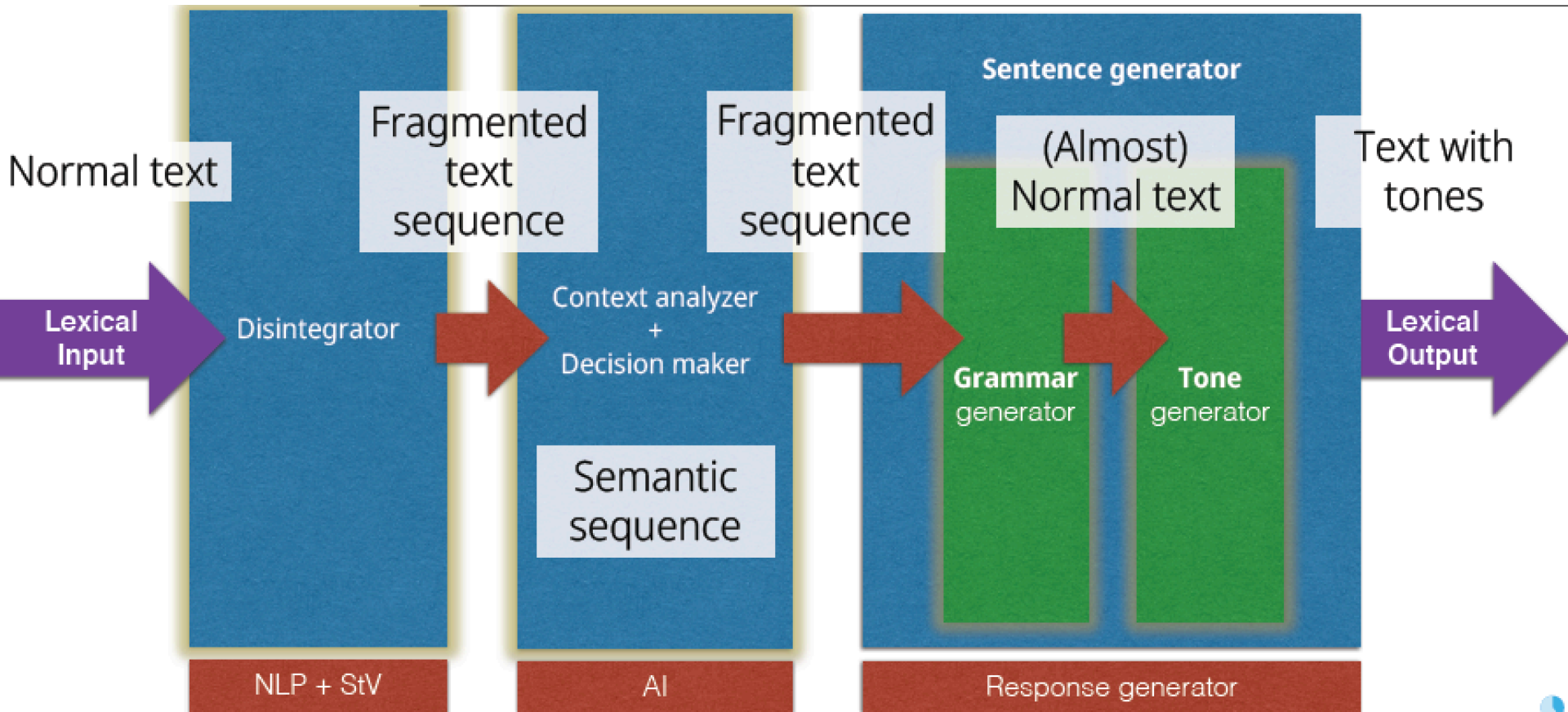

# AI Deep Learning for Chatbot

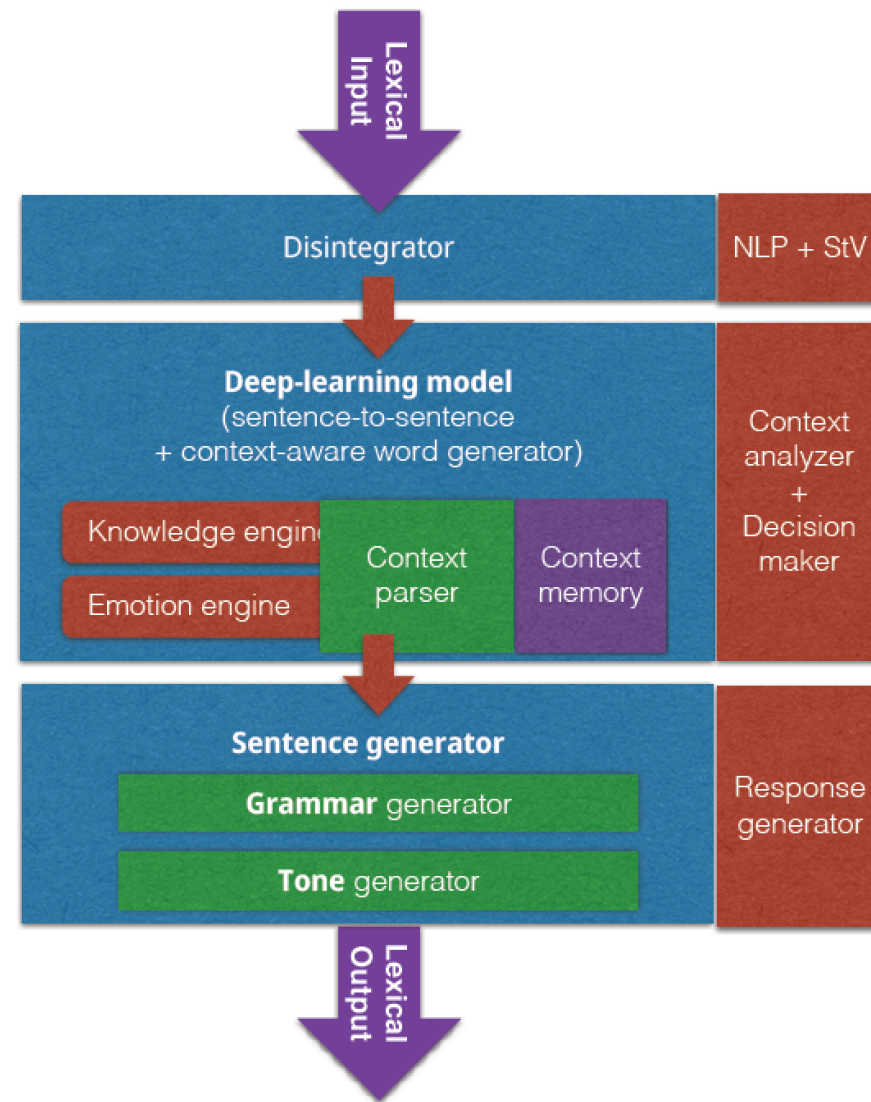
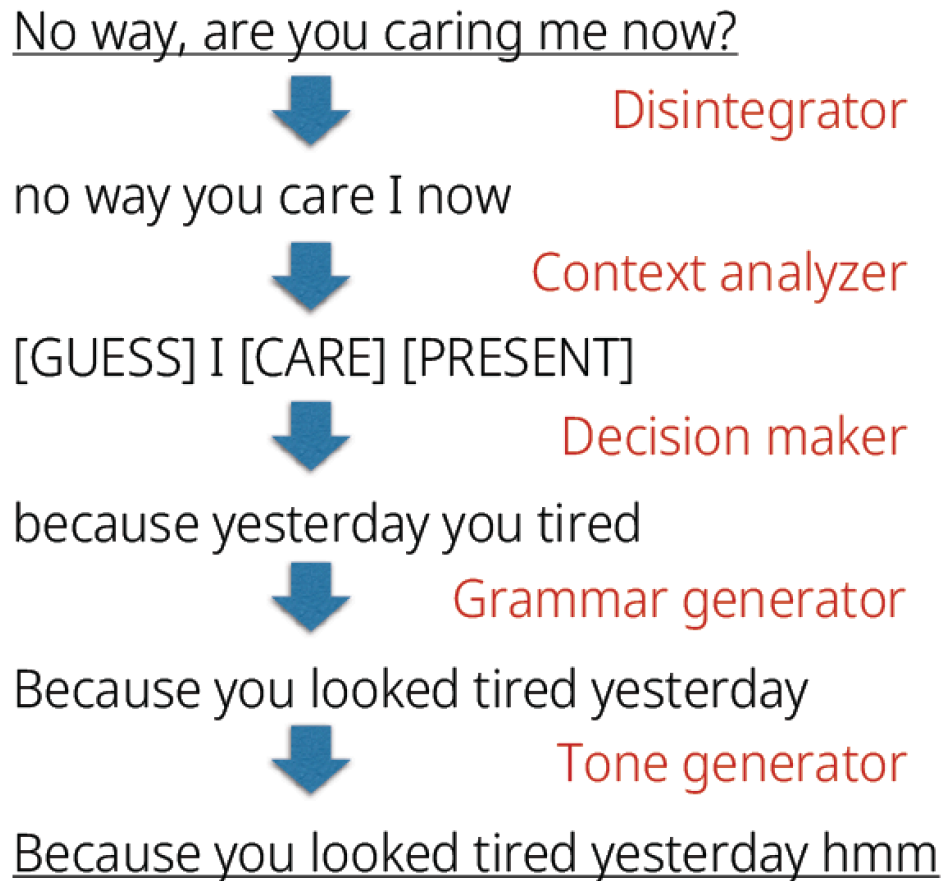

# Data Converter for Chatbot Subtitle Files from Movie

.smi to .srt

**Join**  
.srt files into one .txt

```
cat *.srt >> data.txt
```

**Remove**  
timestamps  
and  
blank lines

**Remove**  
Logo / Ending  
Song scripts

: Lines with  
Japanese  
Characters  
and  
the next lines  
of them

**Fetch**

*Character names*  
*Nouns*  
*Numbers*  
using  
custom dictionary

(Anime characters,  
Locations,  
Specific nouns)

`subtitle_converter.py`



# Data Converter for Chatbot Subtitle Files from Movie

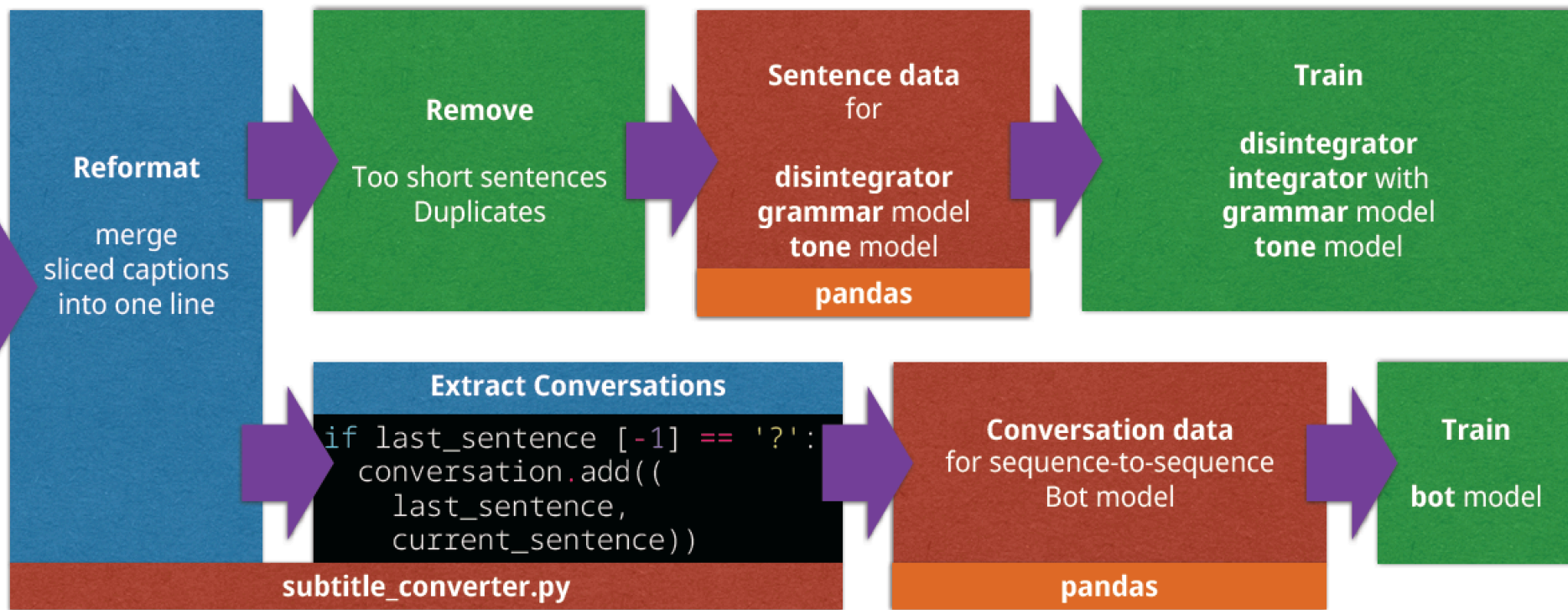

# Conversation Bot Model

- Embedding RNN Sequence-to-sequence model
  - Testing
    - 4-layer to 8-layer swallow learning (without input/output layer)
- Use tensorflow.contrib.learn (formally sklearn package)
  - Simpler and easier than traditional handcrafted RNN
  - Seq2seq, LSTMCell, GRUCell

# Question Answering

# IMTKU Question Answering System for World History Exams at NTCIR-12 QA Lab2

Department of Information Management  
Tamkang University, Taiwan

Sagacity Technology

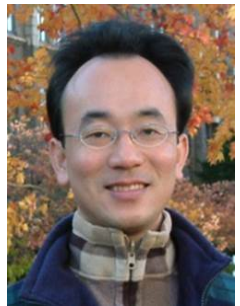

Min-Yuh Day

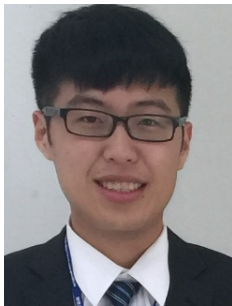

Cheng-Chia Tsai



Wei-Chun Chung



Hsiu-Yuan Chang



Tzu-Jui Sun



Yuan-Jie Tsai



Jin-Kun Lin



Cheng-Hung Lee



Yu-Ming Guo

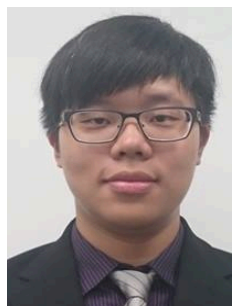

Yue-Da Lin



Wei-Ming Chen

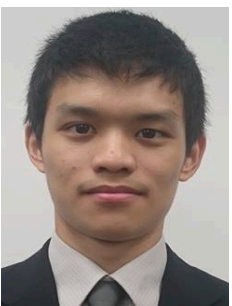

Yun-Da Tsai



Cheng-Jhih Han

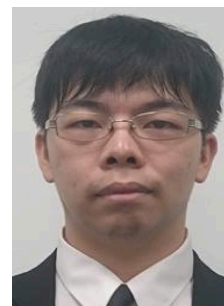

Yi-Jing Lin

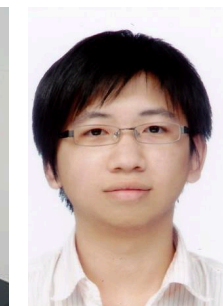

Yi-Heng Chiang



Ching-Yuan Chien

[myday@mail.tku.edu.tw](mailto:myday@mail.tku.edu.tw)

NTCIR-12 Conference, June 7-10, 2016, Tokyo, Japan



# **IMTKU Question Answering System for World History Exams at NTCIR-12 QA Lab2**

# IMTKU Textual Entailment System for Recognizing Inference in Text at NTCIR-9 RITE

Department of Information Management  
Tamkang University, Taiwan

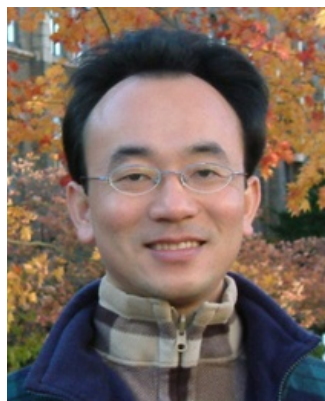

Min-Yuh Day



Chun Tu

[myday@mail.tku.edu.tw](mailto:myday@mail.tku.edu.tw)



# IMTKU Textual Entailment System for Recognizing Inference in Text at NTCIR-10 RITE-2

Department of Information Management  
Tamkang University, Taiwan

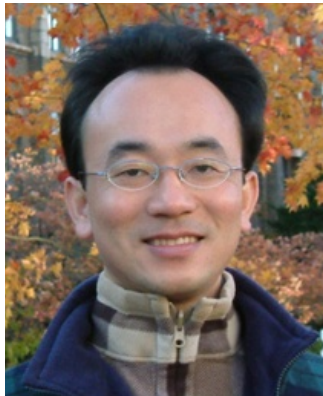

Min-Yuh Day



Chun Tu



Hou-Cheng Vong



Shih-Wei Wu



Shih-Jhen Huang

[myday@mail.tku.edu.tw](mailto:myday@mail.tku.edu.tw)

# IMTKU Textual Entailment System for Recognizing Inference in Text at NTCIR-11 RITE-VAL

Tamkang University

淡江大學

# 2014

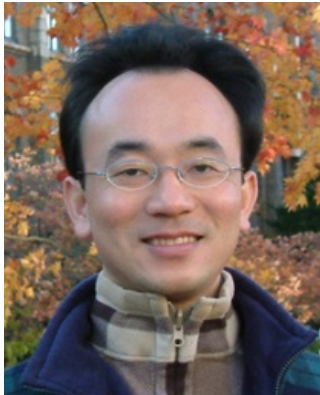

Min-Yuh Day



Ya-Jung Wang



Che-Wei Hsu



En-Chun Tu

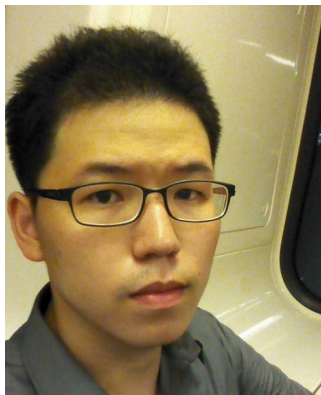

Huai-Wen Hsu



Yu-An Lin

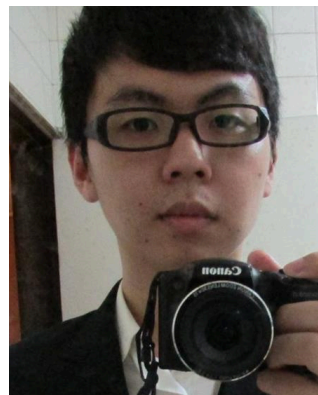

Shang-Yu Wu



Yu-Hsuan Tai



Cheng-Chia Tsai





# IMTKU Question Answering System for World History Exams at NTCIR-12 QA Lab2

Department of Information Management  
Tamkang University, Taiwan

Sagacity Technology

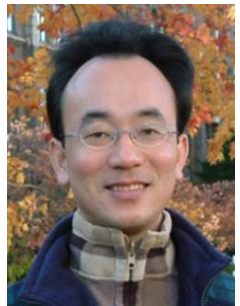

Min-Yuh Day

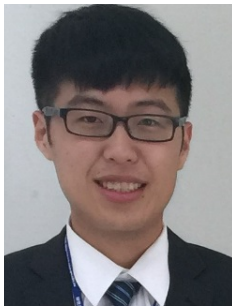

Cheng-Chia Tsai



Wei-Chun Chung



Hsiu-Yuan Chang



Tzu-Jui Sun



Yuan-Jie Tsai



Jin-Kun Lin



Cheng-Hung Lee



Yu-Ming Guo

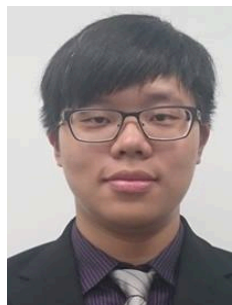

Yue-Da Lin



Wei-Ming Chen

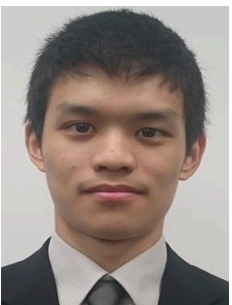

Yun-Da Tsai

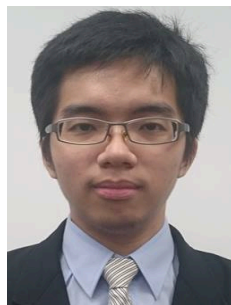

Cheng-Jhih Han



Yi-Jing Lin



Yi-Heng Chiang



Ching-Yuan Chien

[myday@mail.tku.edu.tw](mailto:myday@mail.tku.edu.tw)

NTCIR-12 Conference, June 7-10, 2016, Tokyo, Japan



# Motivation

## Question Answering System

Who was the U.S. president in 2012?

**Barack Obama**

# Highlights

- **IMTKU (Information Management at TamKang University) Question Answering System for World History Exams at NTCIR-12 QA Lab2**
- **Phase-1**
  - 6 End-to-End QA runs results for **English subtask** for National Center Test for University Admissions and Secondary exams subtask.
- **Phase-3**
  - 7 End-to-End QA run results for **English and Japanese subtask** for Nation Center Exams and Secondary exams subtask.

# IMTKU System Architecture for NTCIR-12 QALab2

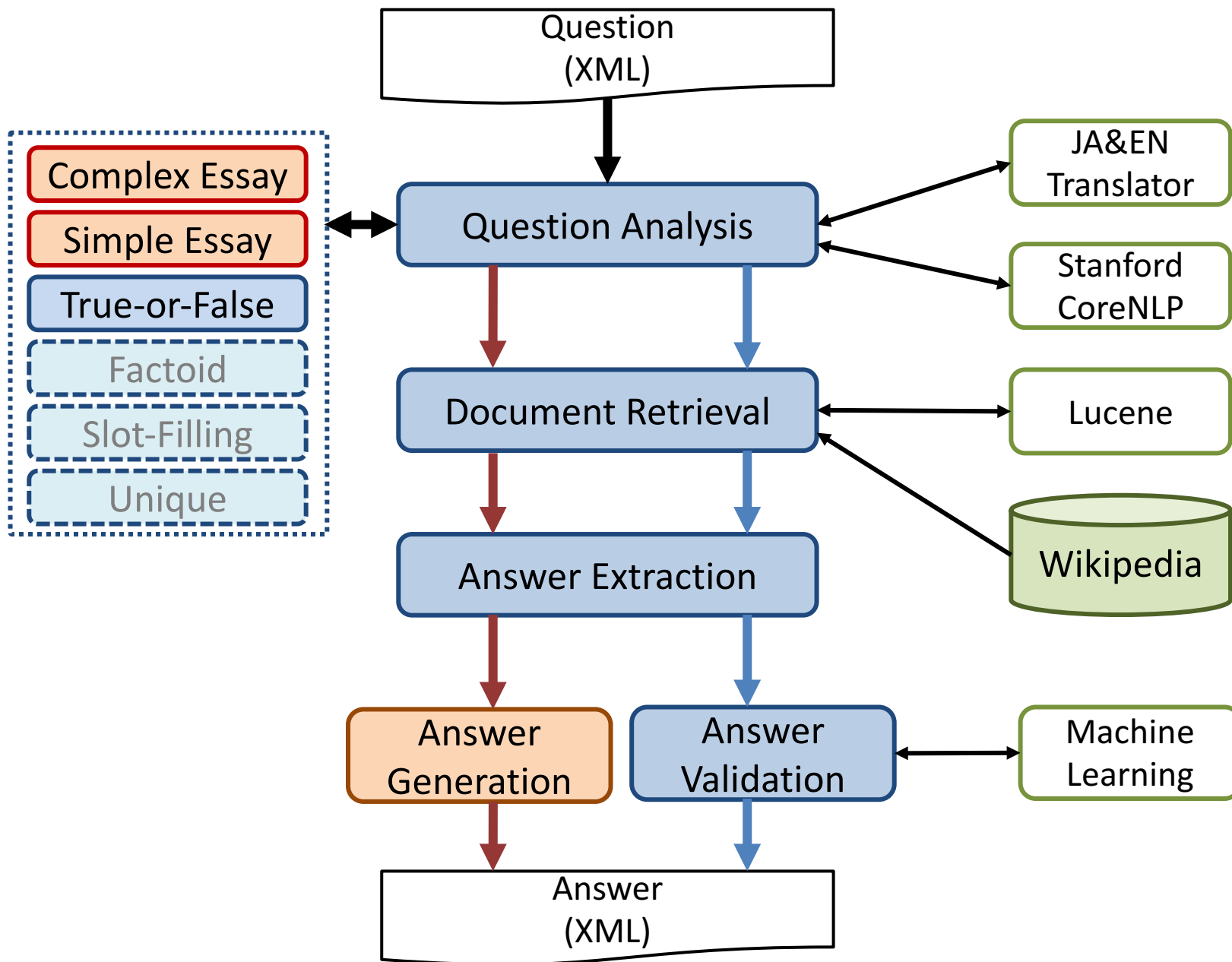



# IMTKU

# System Description

# Question Analysis

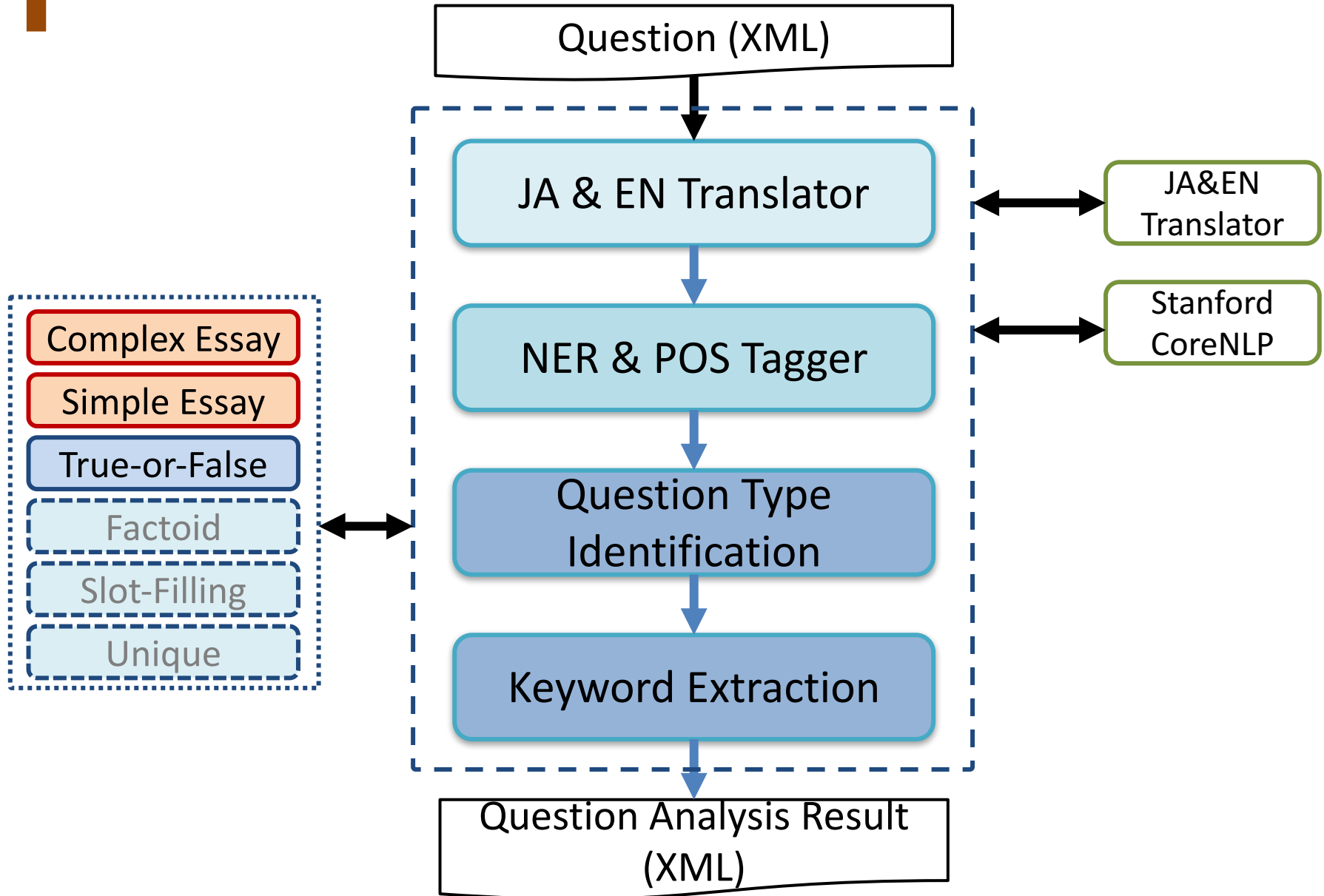

# JA & EN Translator

JA&EN  
Translator

## Japanese:

欧陽脩や蘇軾は，唐代を代表する文筆家である。

## English (provided by organizer):

Ouyang Xiu and Su Shi are writers representative of the Tang period.

## English (JA & EN Translator by Google Translate):

Ouyang Xiu and Su Shi is a writer representative of the Tang Dynasty.



# NER & POS tagger

Stanford  
CoreNLP

## Raw Data:

Wang Anshi, who lived during the Song period, carried out reforms called the New Policies (xin fa).

## POS tagger and NER:

Wang/PERSON/NNP Anshi/PERSON/NNP ,/O/, who/O/WP  
lived/O/VBD during/O/IN the/O/DT Song/O/NN  
period/O/NN ,/O/, carried/O/VBD out/O/RP  
reforms/O/NNS called/O/VBD the/O/DT New/O/JJ  
Policies/O/NNS -LRB-/O/-LRB- xin/O/FW fa/O/FW -RRB-  
/O/-RRB- ./O/.



# Question Analysis Result

```
<KEY_TERM_SET LANGUAGE="EN">  
  <KEY_TERM RANK="1" SCORE="1">time</KEY_TERM>  
  <KEY_TERM RANK="2" SCORE="0.95">Tsuda</KEY_TERM>  
  <KEY_TERM RANK="3" SCORE="0.9">Umeko</KEY_TERM>  
  <KEY_TERM RANK="4" SCORE="0.85">journey</KEY_TERM>  
  <KEY_TERM RANK="5" SCORE="0.8">USA</KEY_TERM>  
  <KEY_TERM RANK="6" SCORE="0.75">China</KEY_TERM>  
  <KEY_TERM RANK="7" SCORE="0.7">language</KEY_TERM>  
  <KEY_TERM RANK="8" SCORE="0.65">schools</KEY_TERM>  
  <KEY_TERM RANK="9" SCORE="0.6">students</KEY_TERM>  
  <KEY_TERM RANK="10" SCORE="0.55">modernization</KEY_TERM>  
  <KEY_TERM RANK="11" SCORE="0.5">policy</KEY_TERM>  
  <KEY_TERM RANK="12" SCORE="0.45">foreign</KEY_TERM>  
  <KEY_TERM RANK="13" SCORE="0.4">government-funded</KEY_TERM>  
  <KEY_TERM RANK="14" SCORE="0.35">Tsuda</KEY_TERM>  
  <KEY_TERM RANK="15" SCORE="0.3">Umeko</KEY_TERM>  
</KEY_TERM_SET>
```

# 2

# Document Retrieval

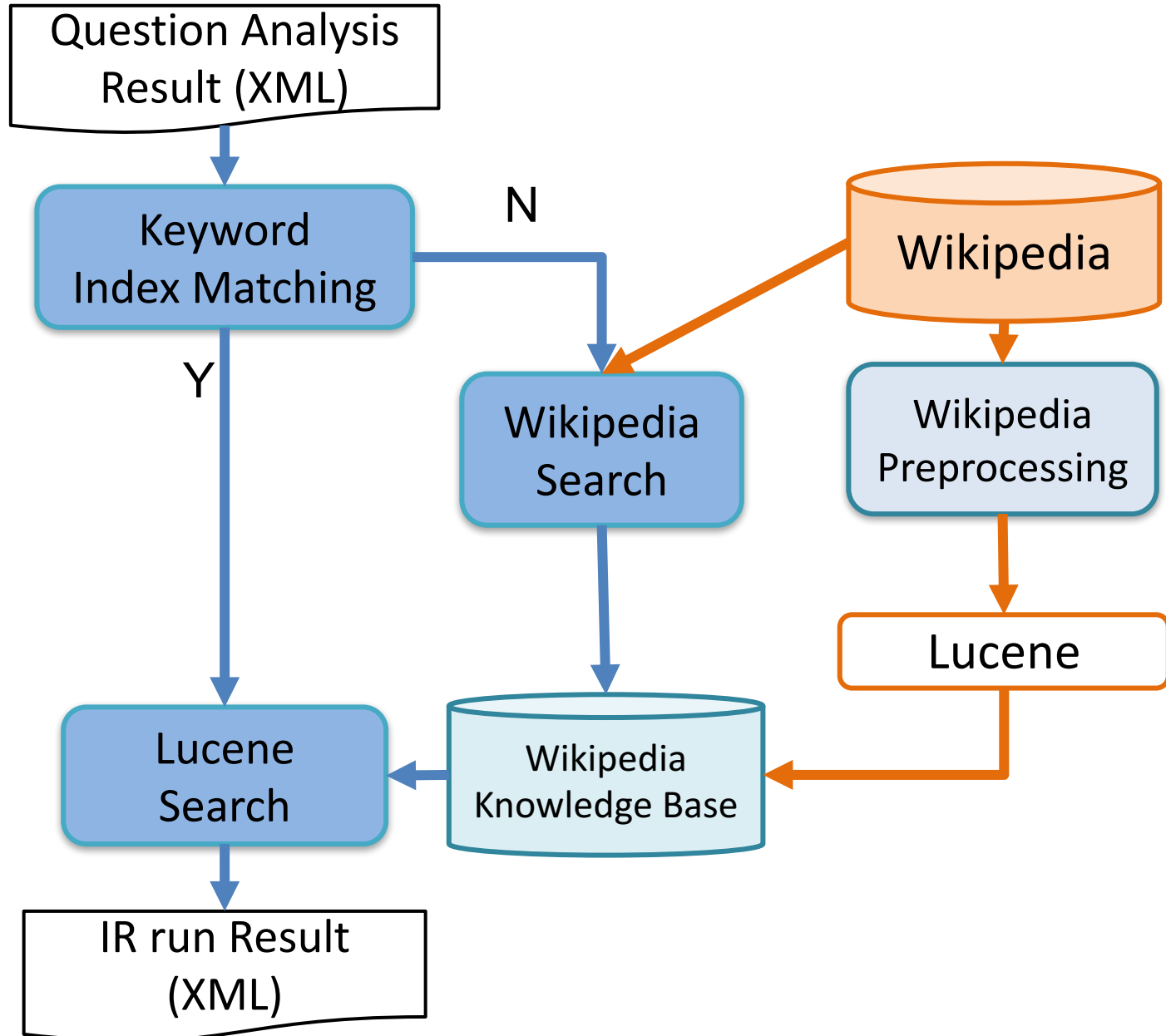

# Document Retrieval Result

```
<DOCUMENT_SET>
  <DOCUMENT RANK="1" SCORE="0.4393864"
SOURCE_ID="https://en.wikipedia.org/wiki/Buddha-nature"
SOURCE_ID_TYPE="WEB">Zen in the USA</DOCUMENT>
  <DOCUMENT RANK="2" SCORE="0.3515091"
SOURCE_ID="https://en.wikipedia.org/wiki/Robert_Smithson"
SOURCE_ID_TYPE="WEB">Spiral Jetty, Utah, USA</DOCUMENT>
  <DOCUMENT RANK="3" SCORE="0.2636318"
SOURCE_ID="https://en.wikipedia.org/wiki/Buddhism_in_China"
SOURCE_ID_TYPE="WEB">Sheng Yen also founded dharma centers in the
USA</DOCUMENT>
  <DOCUMENT RANK="4" SCORE="0.2515581"
SOURCE_ID="https://en.wikipedia.org/wiki/Chinese_language"
SOURCE_ID_TYPE="WEB">Numbers of first-language speakers</DOCUMENT>
  <DOCUMENT RANK="5" SCORE="0.2500338"
SOURCE_ID="https://en.wikipedia.org/wiki/Gloucester,_Massachusetts"
SOURCE_ID_TYPE="WEB">The following schools are located within the Gloucester Public
Schools District:</DOCUMENT>
</DOCUMENT_SET>
```

# 3

# Answer Extraction

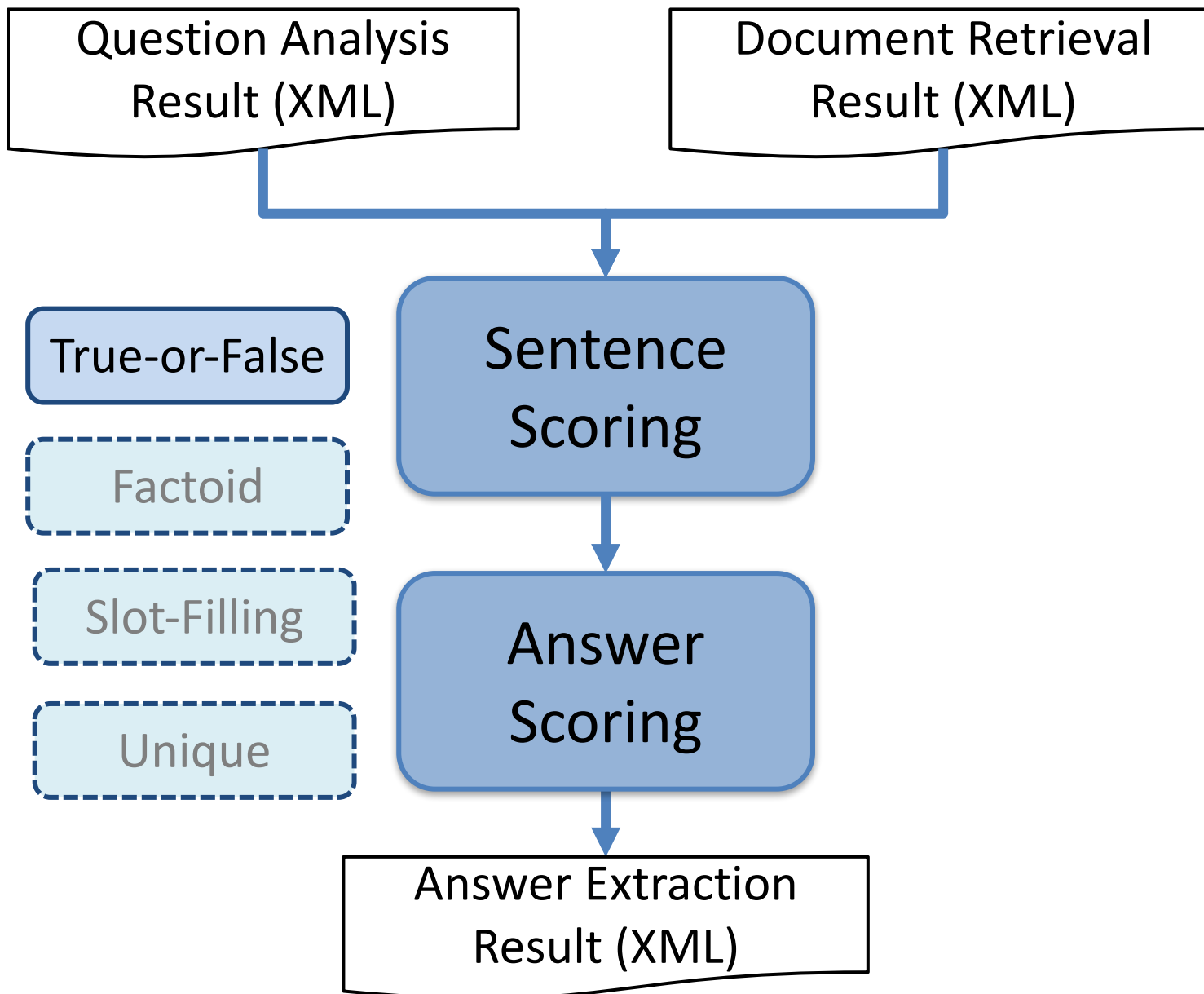

# Answer Extraction Result



<question anscol="A1" target="time">

<keyList>

<mainKey>Imperial</mainKey>

<mainKey>Tang</mainKey>

<mainKey>Song</mainKey>

<mainKey>onwards</mainKey>

<mainKey>culture</mainKey>

<viceKey>song</viceKey>

<viceKey>tang</viceKey>

</keyList>

<sentenceList>

<sentence>During this time, the Song court retreated south of the Yangtze River and established their capital at Lin'an. Although the Song Dynasty had lost control of the traditional birthplace of Chinese civilization along the Yellow River, the Song economy was not in ruins, as the Southern Song Empire contained 60 percent of China's population and a majority of the most productive agricultural land</sentence>

<sentence>Southern Tang was conquered in 976 by the Northern Song Dynasty</sentence>

</sentenceList>

<answerList>

<A><answer>Ouyang Xiu and Su Shi are writers representative of the Tang period.</answer></A>

<B><answer>Yan Zhenqing is a calligrapher representative of the Song period.</answer></B>

<C><answer>Wang Anshi, who lived during the Song period, carried out reforms called the New Policies (xin fa).</answer></C>

<D><answer>Qin Hui came into conflict with the party in favor of war, concerning the relationship with the Yuan.</answer></D>

</answerList>

</question>

# 4

# Answer Generation

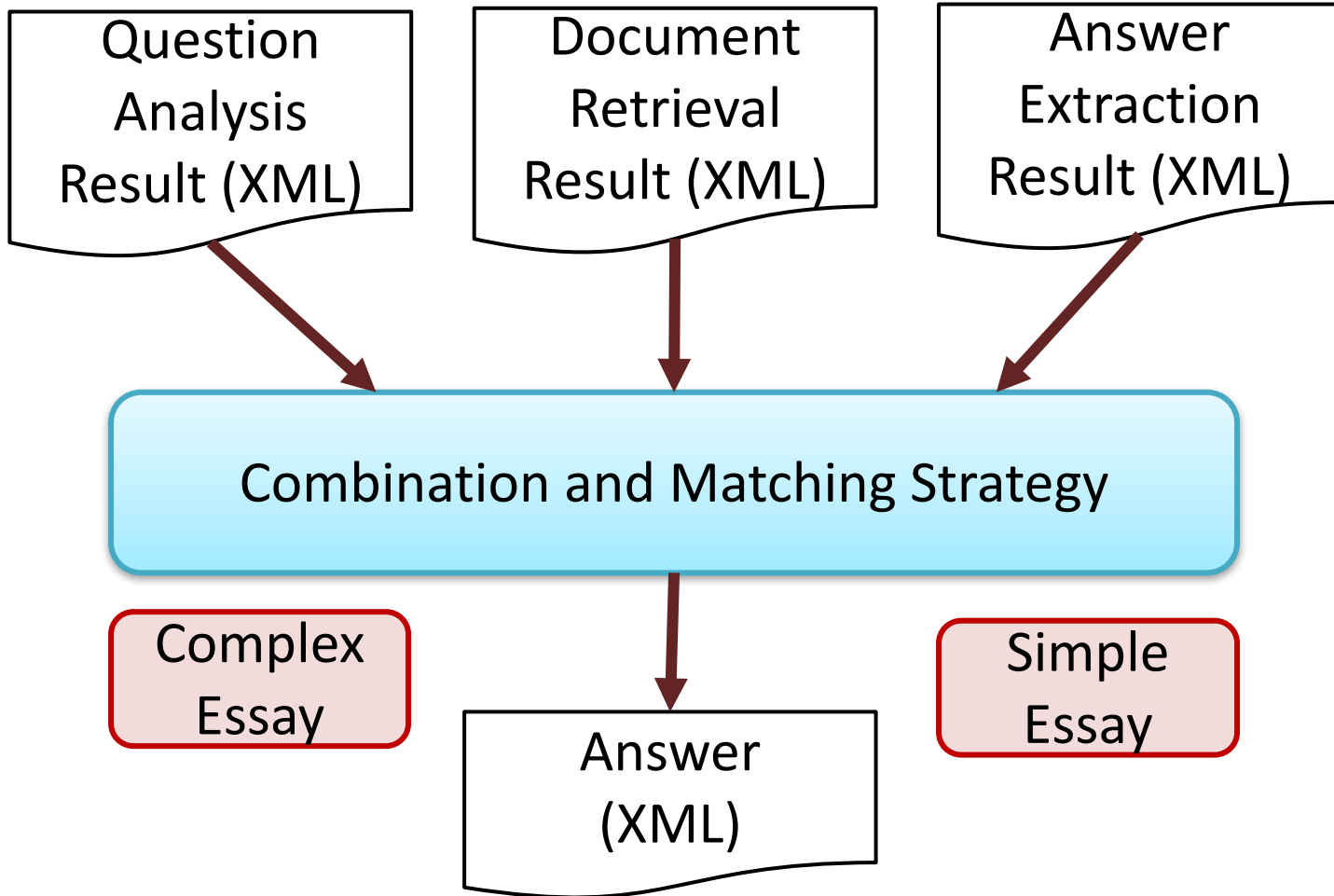

# Answer Generation Result

```
<answer match_type="exact" order="-1" choices="" format_string=""
length_limit="-1">
  <expression_set>
    <expression>
      Jessica Motaung
    </expression>
  </expression_set>
</answer>
```



# 5

# Answer Validation

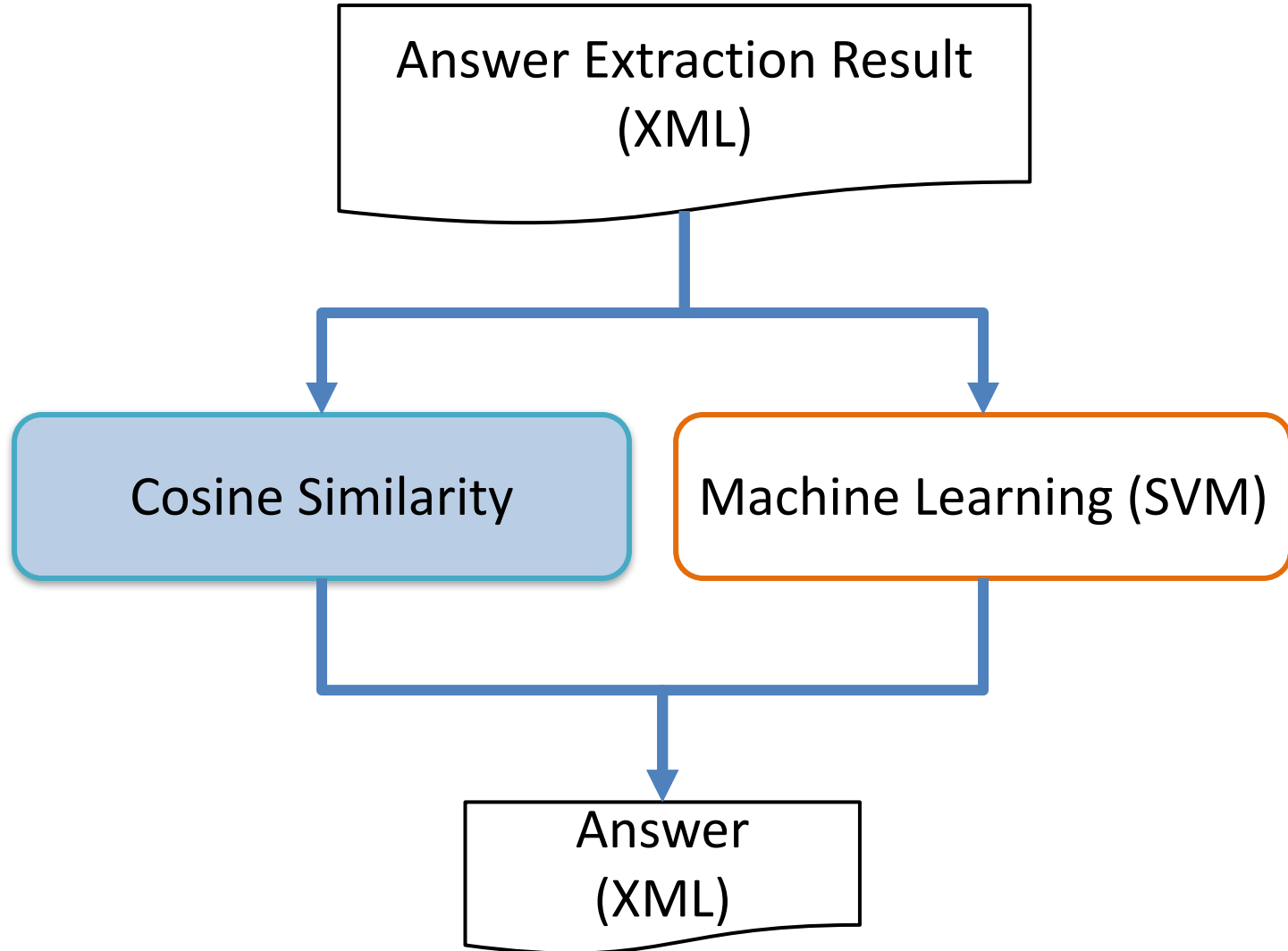

# Answer Validation Result

<combine>

<sentence>China is the largest trading nation in the world and plays a vital role in international trade, and has increasingly engaged in trade organizations and treaties in recent years</sentence>

<answer>Song is to manage maritime trade, established a Maritime Affairs.</answer>

<option>1</option>

<dict>0.177122977108019</dict>

</combine>

<combine>

<sentence>China is the largest trading nation in the world and plays a vital role in international trade, and has increasingly engaged in trade organizations and treaties in recent years</sentence>

<answer>In the Middle Ages of the Champagne region, large-scale regular city is opened.</answer>

<option>2</option>

<dict>0.180775381515547</dict>

</combine>

<combine>

# Dialogue System

# Dialogue System

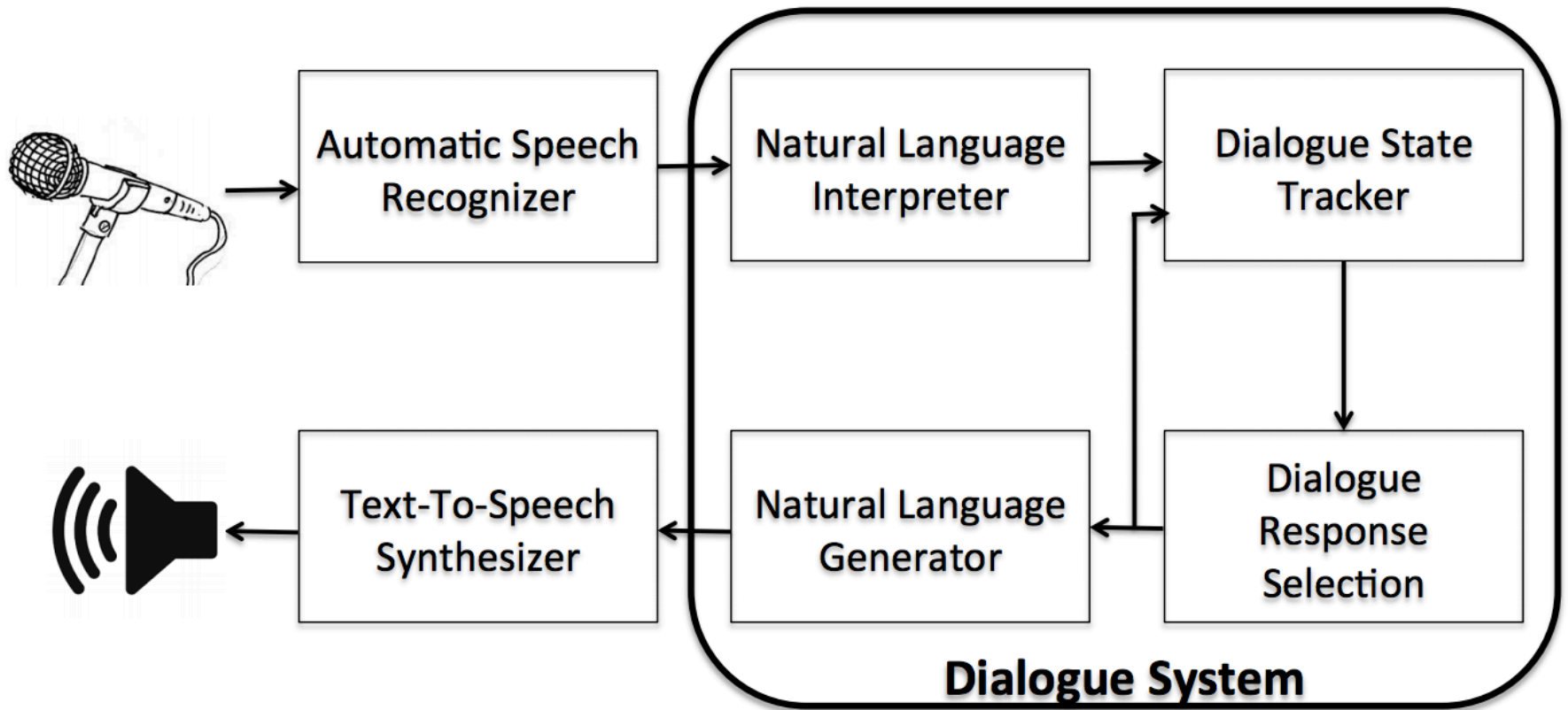

# Chat-oriented Dialogue System

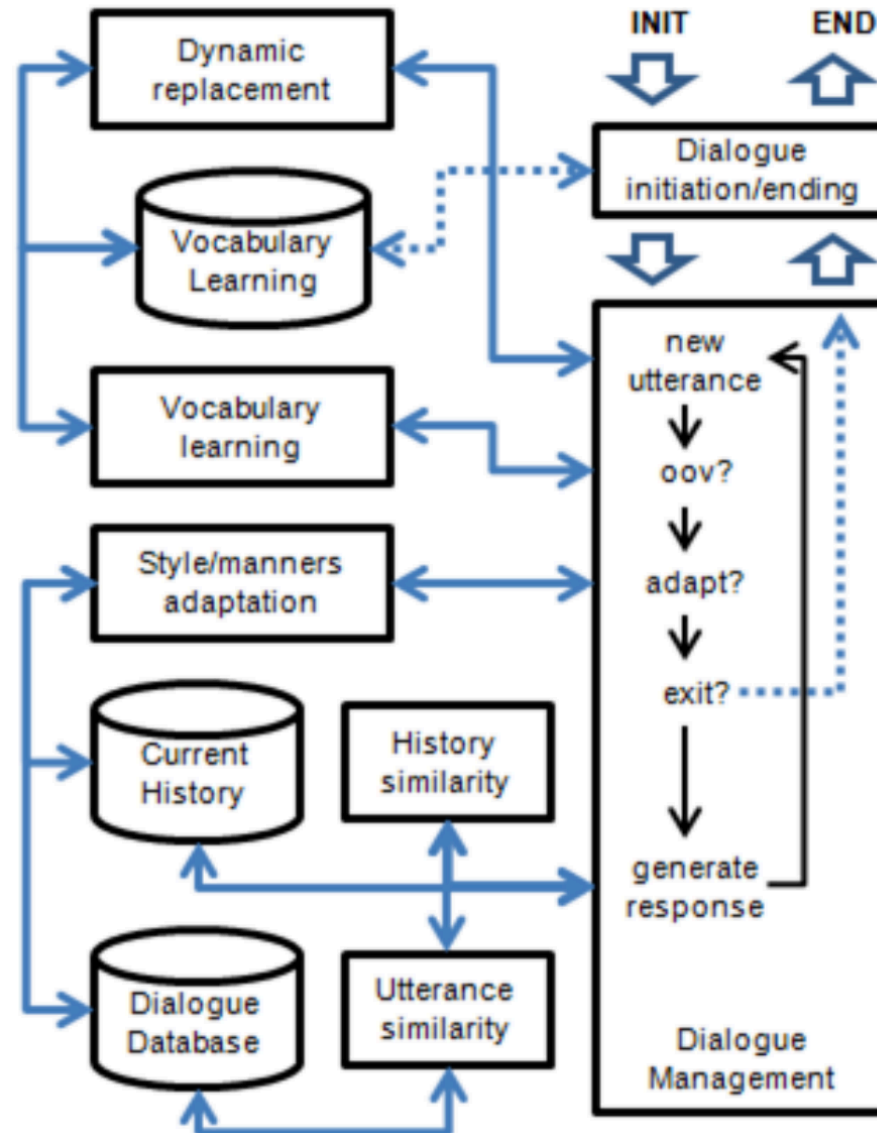

# AIML Dialogue System

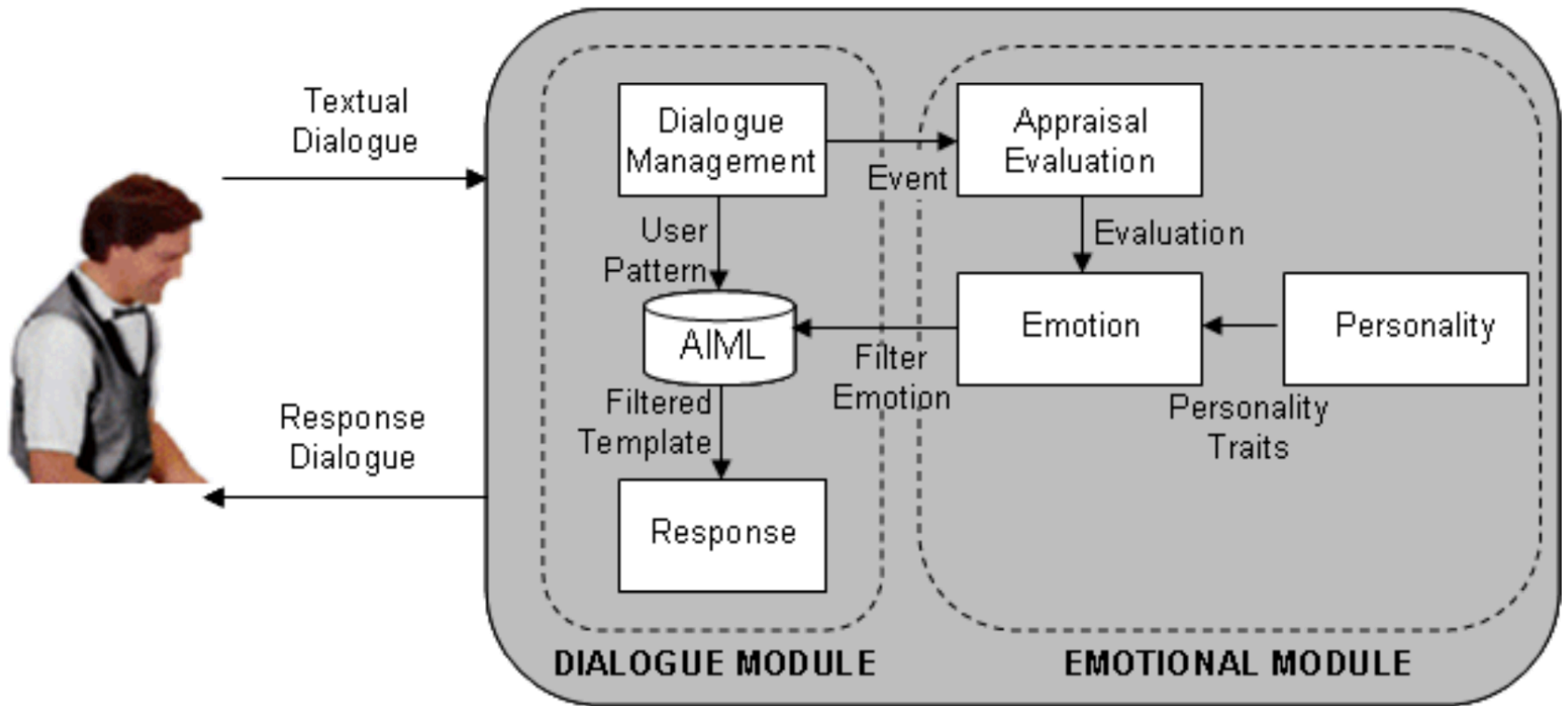

# ALICE and AIML



Free Live Chat with the award winning A. I. chat robot **A. L. I. C. E.**

## Get Started

[Chat with A.L.I.C.E.](#)

[Chat with Fake Kirk](#)

[What is AIML?](#)  
[Foundation Bot Directory](#)  
[Bot Industry Survey](#)  
[AIML Overview](#)

## Software

[Downloads](#)  
[Bot Hosting](#)  
[AIML Sets](#)  
[AIML 1.1 Specification](#)  
[AIML 2.0 Working Draft](#)  
[Documentation](#)  
[Superbot - New!](#)

## Links

[ESL](#)  
[Books](#)  
[Film and TV](#)  
[Recent Press](#)  
[Popular Culture](#)  
[Web Ontologies](#)  
[ALICE and A.I. History](#)  
[Scholarly Research and Teaching](#)

Site Info
alicebot.org
Rank: 257,092
Links in: 638

## AIML: Artificial Intelligence Markup Language

AIML (Artificial Intelligence Markup Language) is an XML-compliant language that's easy to learn, and makes it possible for you to begin customizing an Alicebot or creating one from scratch within minutes.

The most important units of AIML are:

- `<aiml>`: the tag that begins and ends an AIML document
- `<category>`: the tag that marks a "unit of knowledge" in an Alicebot's knowledge base
- `<pattern>`: used to contain a simple pattern that matches what a user may say or type to an Alicebot
- `<template>`: contains the response to a user input

There are also 20 or so additional more tags often found in AIML files, and it's possible to create your own so-called "custom predicates". Right now, a beginner's guide to AIML can be found in the [AIML Primer](#).

The free **A.L.I.C.E. AIML** includes a knowledge base of approximately 41,000 categories. Here's an example of one of them:

```
<category>
  <pattern>WHAT ARE YOU</pattern>
  <template>
    <think><set name="topic">Me</set></think>
    I am the latest result in artificial intelligence,
    which can reproduce the capabilities of the human brain
    with greater speed and accuracy.
  </template>
</category>
```

(The opening and closing `<aiml>` tags are not shown here, because this is an excerpt from the middle of a document.)

Everything between `<category>` and `</category>` is -- you guessed it -- a category. A category can have one pattern and one template. (It can also contain a `<that>` tag, but we won't get into that here.)

The pattern shown will match *only* the exact phrase "what are you" (capitalization is ignored).

But it's possible that this category may be invoked by another category, using the `<srail>` tag (not shown) and the principle of **reductionism**.

In any case, if this category is called, it will produce the response "I am the latest result in artificial intelligence..." shown above. In addition, it will do something else interesting. Using the `<think>` tag, which causes Alicebot to perform whatever it contains but hide the result from the user, the Alicebot engine will set the "topic" in its memory to "Me". This allows any categories elsewhere with an

## Subscription Bots

[A.L.I.C.E. Silver Edition](#)  
[DAVE E.S.L. Bot](#)  
[CLAUDIO Personality Test](#)

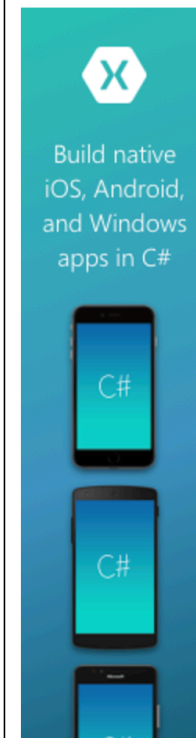



# AIML

## (Artificial Intelligence Markup Language)

<category>

<pattern>HELLO</pattern>

<template>Hi, I am a robot</template>

</category>

# AIML

## (Artificial Intelligence Markup Language)

- `<aiml>`
  - the tag that begins and ends an AIML document
- `<category>`
  - the tag that marks a "unit of knowledge" in an Alicebot's knowledge base
- `<pattern>`
  - used to contain a simple pattern that matches what a **user** may say or type to an Alicebot
- `<template>`
  - contains the **response** to a user input

# AIML

## (Artificial Intelligence Markup Language)

```
<category>
```

```
  <pattern>WHAT ARE YOU</pattern>
```

```
  <template>
```

```
    <think><set name="topic">Me</set></think>
```

```
    I am the latest result in artificial intelligence,  
    which can reproduce the capabilities of the human brain  
    with greater speed and accuracy.
```

```
  </template>
```

```
</category>
```

# Humorist Chat-bot

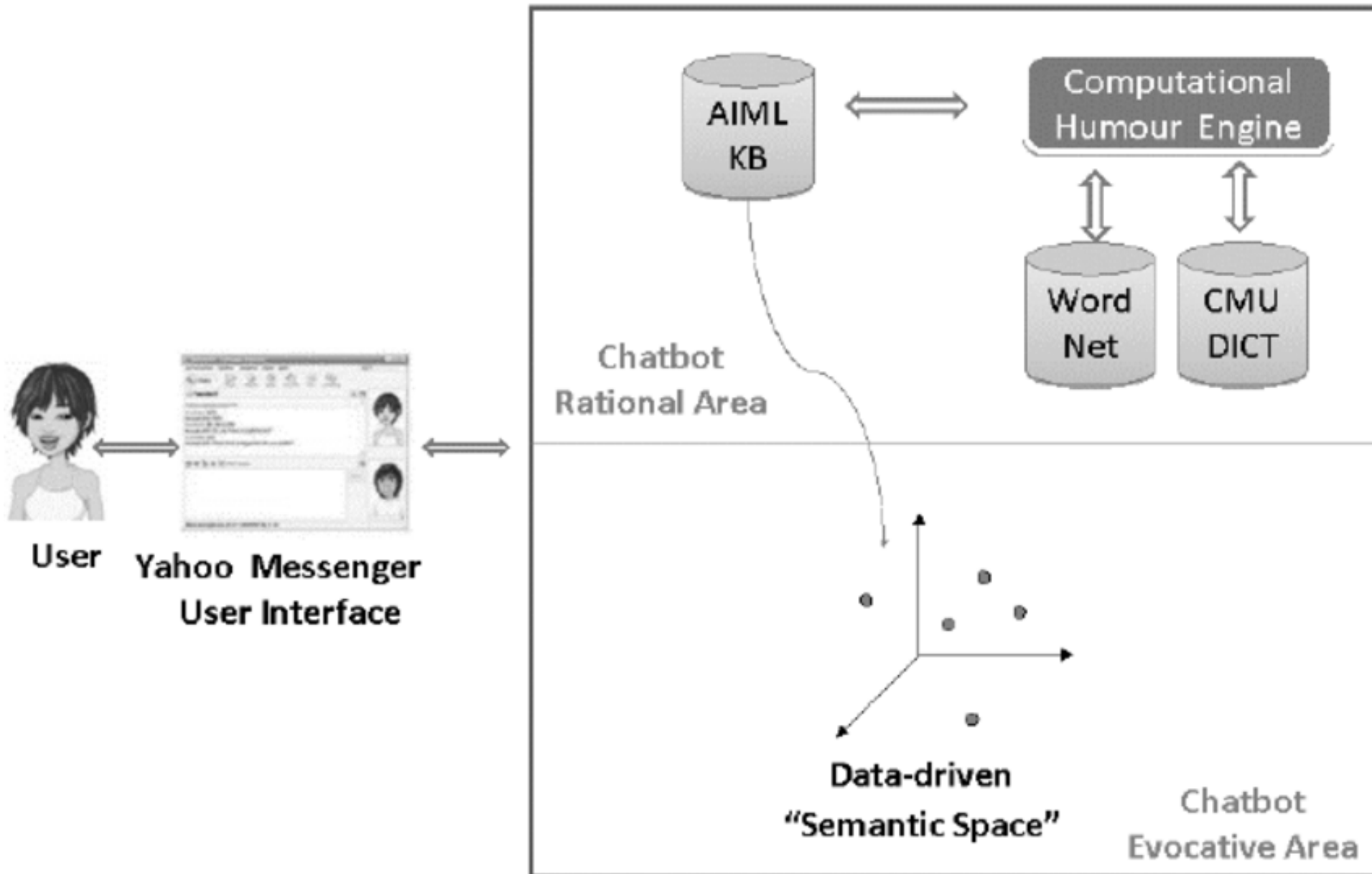

# Ask Me Anything: Dynamic Memory Networks for Natural Language Processing

# Dynamic Memory Networks (DMN)

- I: Jane went to the hallway.
- I: Mary walked to the bathroom.
- I: Sandra went to the garden.
- I: Daniel went back to the garden.
- I: Sandra took the milk there.
- Q: **Where is the milk?**

# Dynamic Memory Networks (DMN)

- I: Jane went to the hallway.
- I: Mary walked to the bathroom.
- I: Sandra went to the garden.
- I: Daniel went back to the garden.
- I: Sandra took the milk there.
- Q: **Where is the milk?**
- A: garden

# Dynamic Memory Networks (DMN)

- I: Jane went to the hallway.
- I: Mary walked to the bathroom.
- I: Sandra went to the garden.
- I: Daniel went back to the garden.
- I: Sandra took the milk there.
- Q: **Where is the milk?**
- A: garden
- I: It started boring, but then it got interesting.
- Q: **What's the sentiment?**
- A: positive
- Q: POS tags?
- A: PRP VBD JJ , CC RB PRP VBD JJ .



# Dynamic Memory Networks (DMN)

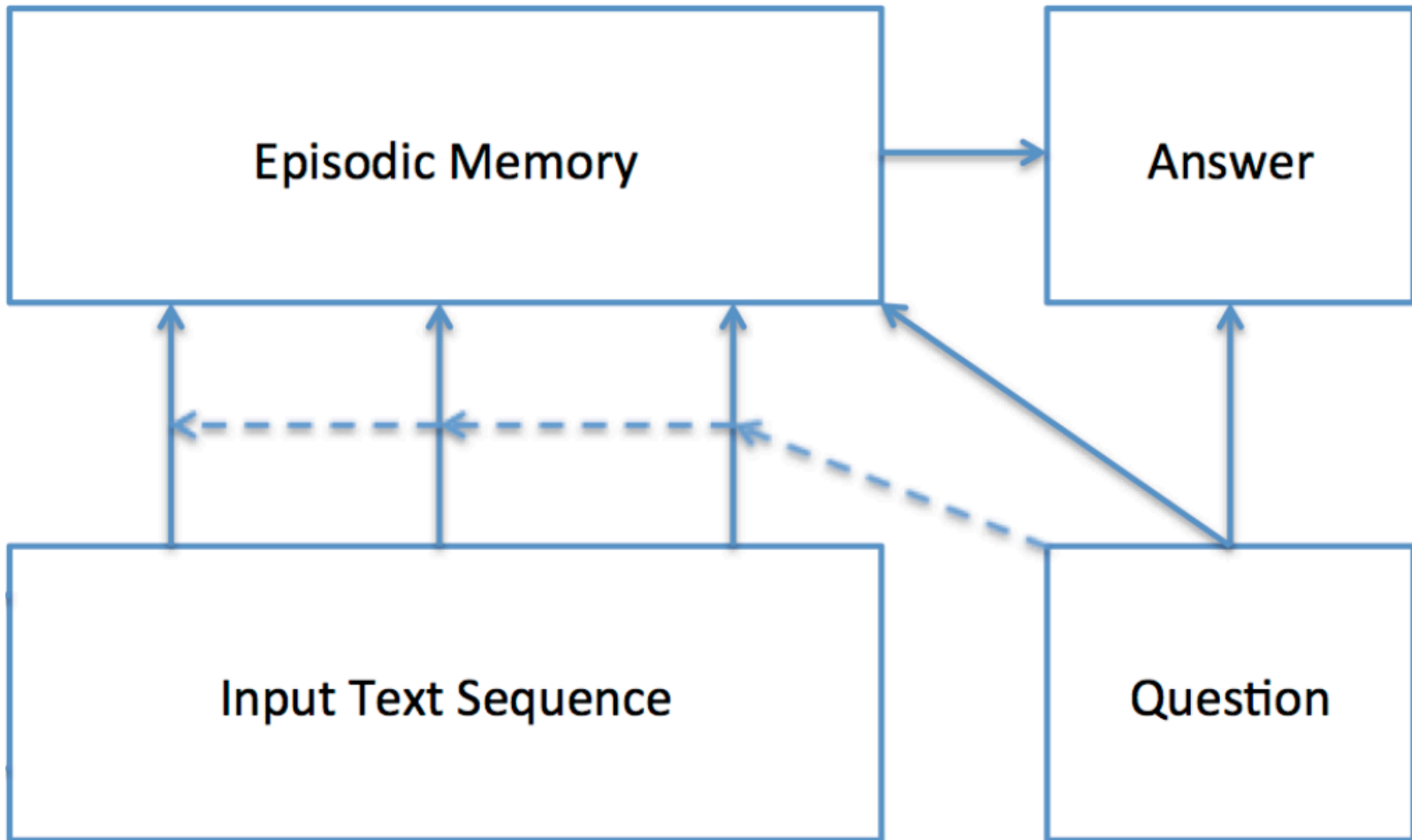

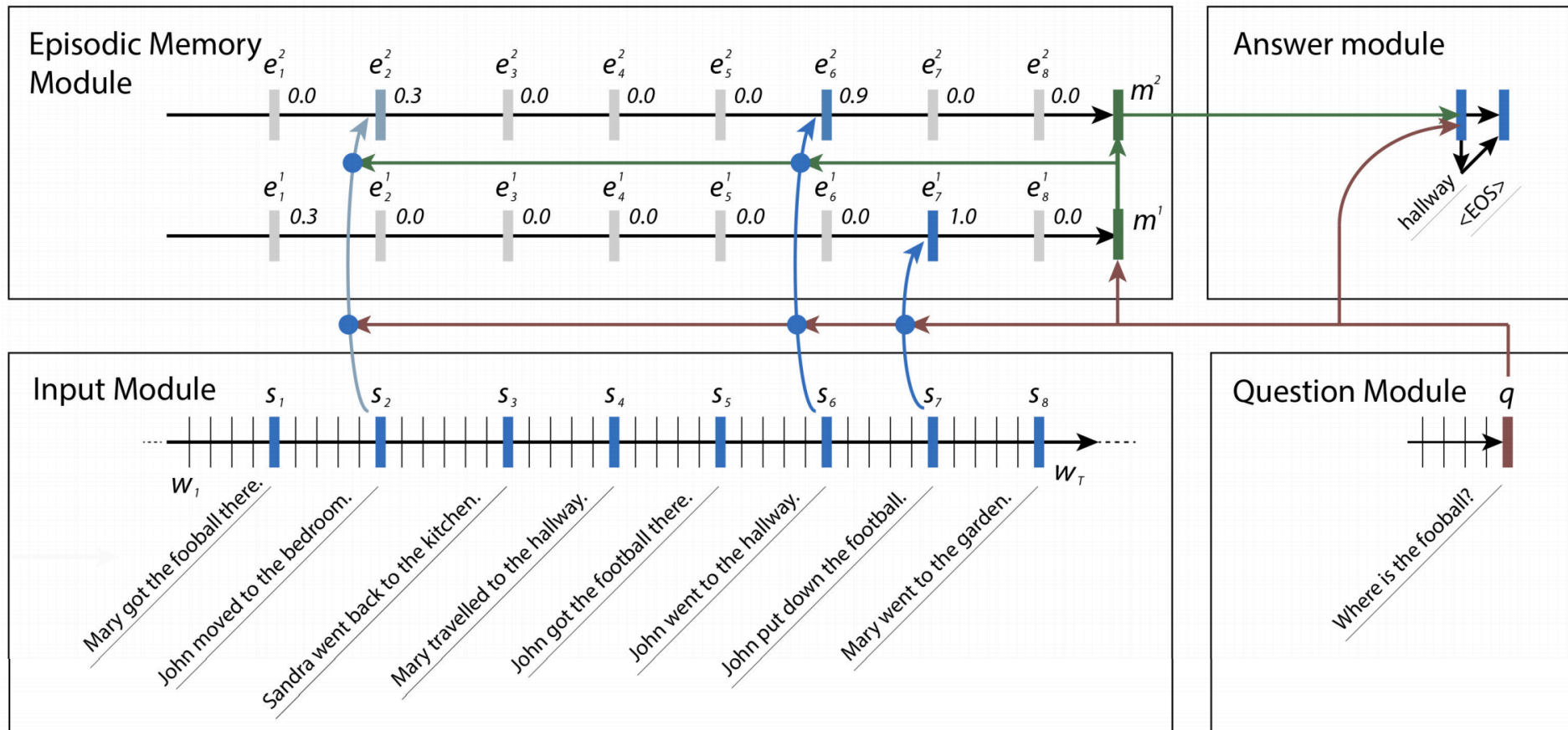

# Dynamic Memory Networks (DMN)



# Dynamic Memory Networks (DMN)

Question: **Where was Mary before the Bedroom?**



Facts	Episode 1	Episode 2	Episode 3
Yesterday Julie traveled to the school.			
Yesterday Marie went to the cinema.			
This morning Julie traveled to the kitchen.			
Bill went back to the cinema yesterday.			
Mary went to the bedroom this morning.			
Julie went back to the bedroom this afternoon.			
[done reading]			

# Dynamic Memory Networks (DMN)

Question: **Where was Mary before the Bedroom?**

Answer: **Cinema.**

---

Facts	Episode 1	Episode 2	Episode 3
Yesterday Julie traveled to the school.			
Yesterday Marie went to the cinema.			
This morning Julie traveled to the kitchen.			
Bill went back to the cinema yesterday.			
Mary went to the bedroom this morning.			
Julie went back to the bedroom this afternoon.			
[done reading]			

---

# Dynamic Memory Networks for Visual and Textual Question Answering

# Question Answering with Dynamic Memory Network (DMN+)

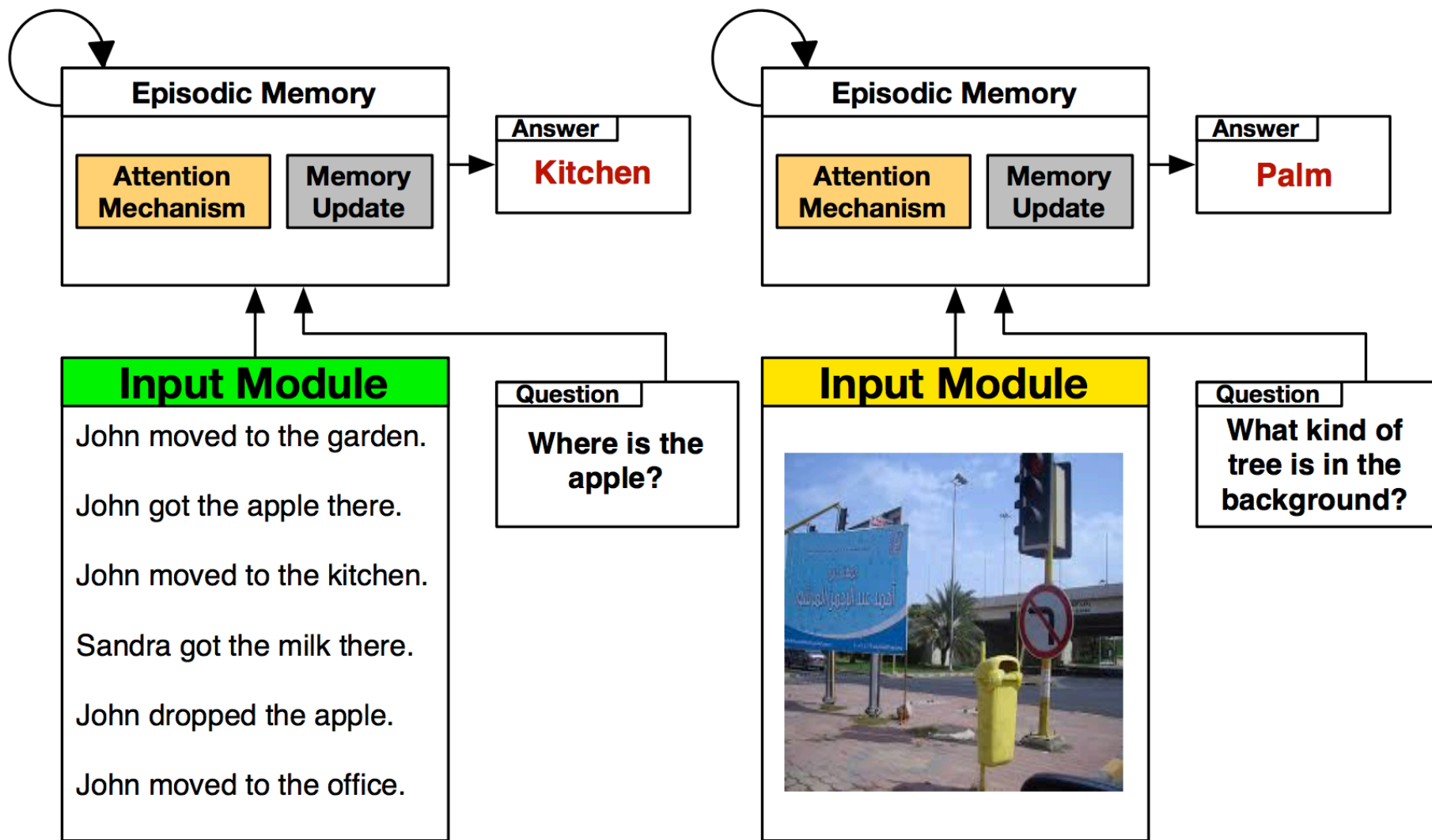

# Dynamic Memory Network (DMN+)

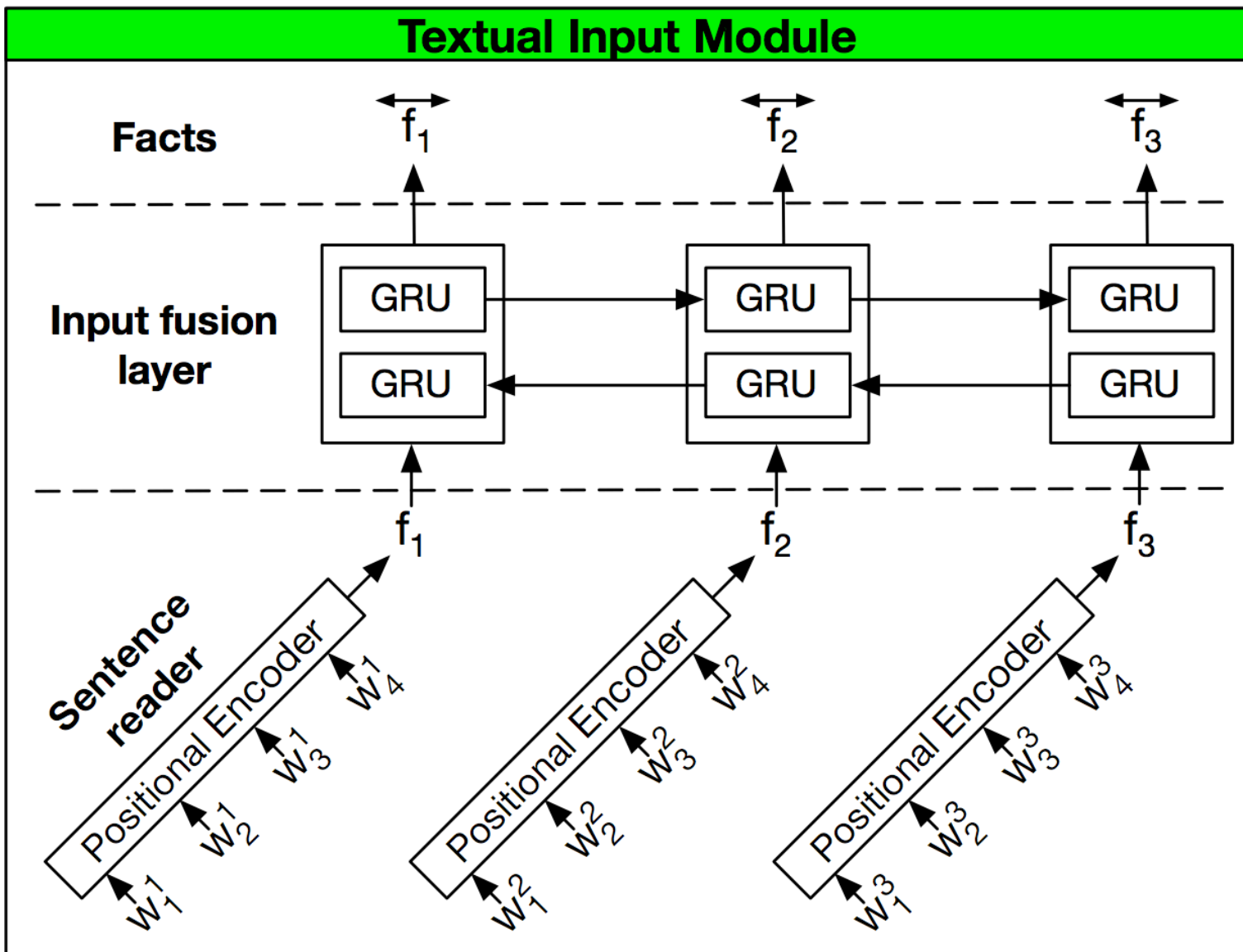

# Dynamic Memory Network (DMN+)

## Episodic Memory Module of the DMN+

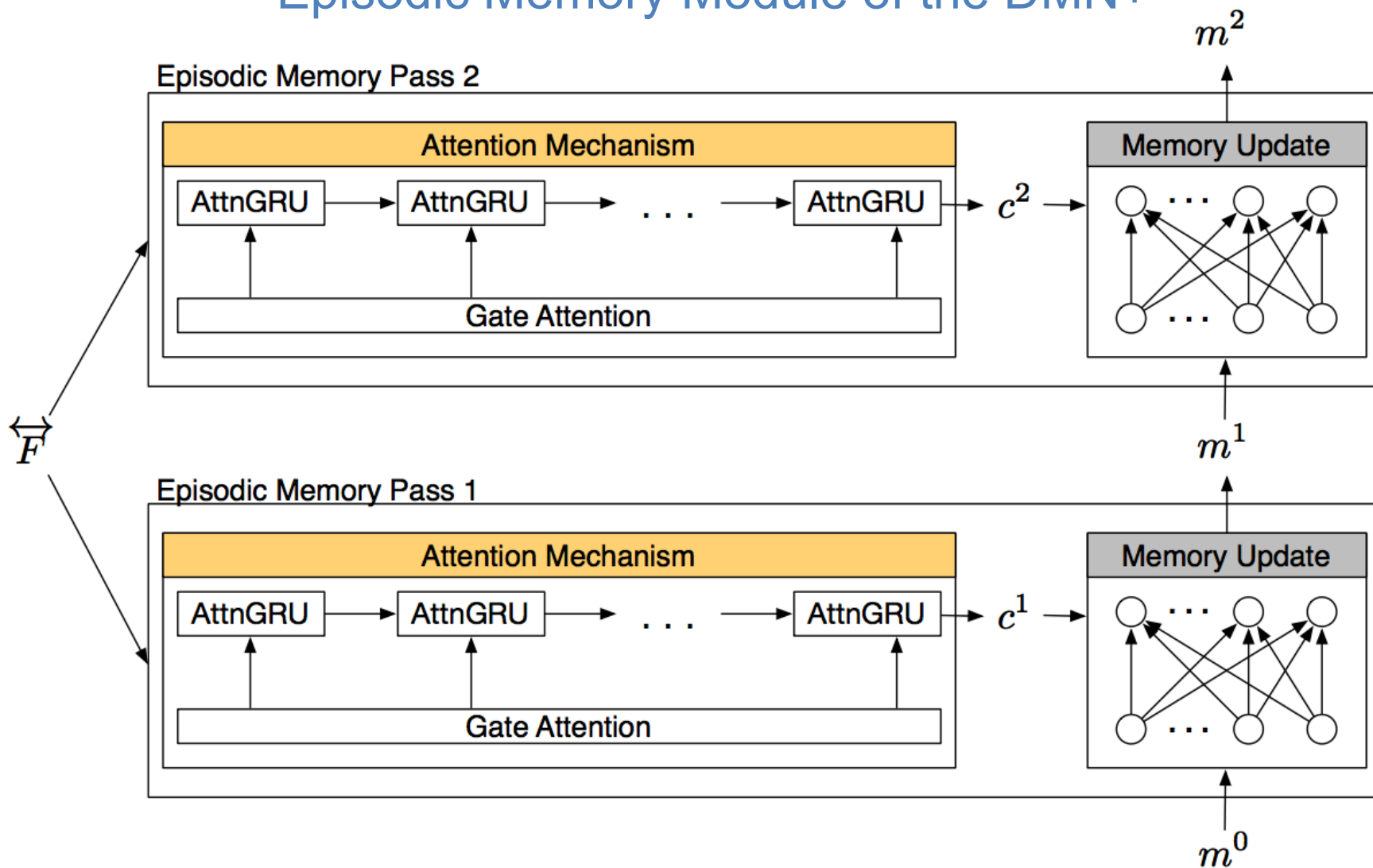



# Differentiable Neural Computer (DNC)

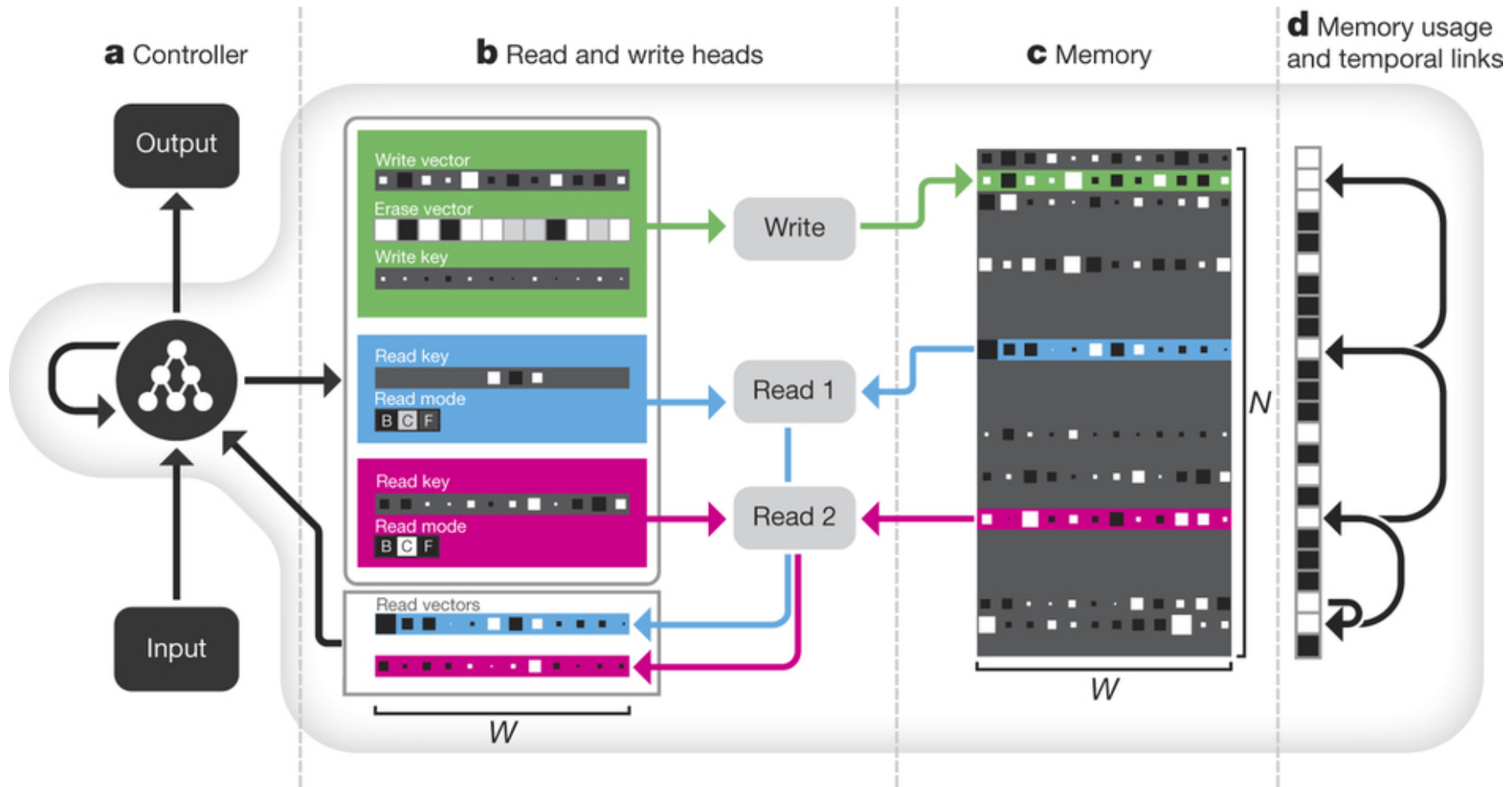

# Facebook AI Research :

## bAbI Project

- The (20) QA bAbI tasks
- The (6) dialog bAbI tasks
- The Children's Book Test
- The Movie Dialog dataset
- The WikiMovies dataset
- The Dialog-based Language Learning dataset
- The SimpleQuestions dataset

# Facebook bAbI QA Datasets

- 1 Mary moved to the bathroom.
- 2 John went to the hallway.
- 3 Where is Mary? bathroom 1
- 4 Daniel went back to the hallway.
- 5 Sandra moved to the garden.
- 6 Where is Daniel? hallway 4
- 7 John moved to the office.
- 8 Sandra journeyed to the bathroom.
- 9 Where is Daniel? hallway 4
- 10 Mary moved to the hallway.
- 11 Daniel travelled to the office.
- 12 Where is Daniel? office 11
- 13 John went back to the garden.
- 14 John moved to the bedroom.
- 15 Where is Sandra? bathroom 8
- 1 Sandra travelled to the office.
- 2 Sandra went to the bathroom.
- 3 Where is Sandra? bathroom 2

# Facebook bAbI QA Datasets

## Task 1: Single Supporting Fact

Mary went to the bathroom.  
John moved to the hallway.  
Mary travelled to the office.  
Where is Mary? A:office

## Task 2: Two Supporting Facts

John is in the playground.  
John picked up the football.  
Bob went to the kitchen.  
Where is the football? A:playground

## Task 3: Three Supporting Facts

John picked up the apple.  
John went to the office.  
John went to the kitchen.  
John dropped the apple.  
Where was the apple before the kitchen? A:office

## Task 4: Two Argument Relations

The office is north of the bedroom.  
The bedroom is north of the bathroom.  
The kitchen is west of the garden.  
What is north of the bedroom? A: office  
What is the bedroom north of? A: bathroom

## Task 5: Three Argument Relations

Mary gave the cake to Fred.  
Fred gave the cake to Bill.  
Jeff was given the milk by Bill.  
Who gave the cake to Fred? A: Mary  
Who did Fred give the cake to? A: Bill

## Task 6: Yes/No Questions

John moved to the playground.  
Daniel went to the bathroom.  
John went back to the hallway.  
Is John in the playground? A:no  
Is Daniel in the bathroom? A:yes

# Facebook bAbI QA Datasets

## Task 7: Counting

Daniel picked up the football.  
Daniel dropped the football.  
Daniel got the milk.  
Daniel took the apple.  
How many objects is Daniel holding? **A: two**

## Task 8: Lists/Sets

Daniel picks up the football.  
Daniel drops the newspaper.  
Daniel picks up the milk.  
John took the apple.  
What is Daniel holding? **milk, football**

## Task 9: Simple Negation

Sandra travelled to the office.  
Fred is no longer in the office.  
Is Fred in the office? **A:no**  
Is Sandra in the office? **A:yes**

## Task 10: Indefinite Knowledge

John is either in the classroom or the playground.  
Sandra is in the garden.  
Is John in the classroom? **A:maybe**  
Is John in the office? **A:no**

## Task 11: Basic Coreference

Daniel was in the kitchen.  
Then he went to the studio.  
Sandra was in the office.  
Where is Daniel? **A:studio**

## Task 12: Conjunction

Mary and Jeff went to the kitchen.  
Then Jeff went to the park.  
Where is Mary? **A: kitchen**  
Where is Jeff? **A: park**

## Task 13: Compound Coreference

Daniel and Sandra journeyed to the office.  
Then they went to the garden.  
Sandra and John travelled to the kitchen.  
After that they moved to the hallway.  
Where is Daniel? **A: garden**

## Task 14: Time Reasoning

In the afternoon Julie went to the park.  
Yesterday Julie was at school.  
Julie went to the cinema this evening.  
Where did Julie go after the park? **A:cinema**  
Where was Julie before the park? **A:school**

# Facebook bAbI QA Datasets

## Task 15: Basic Deduction

Sheep are afraid of wolves.

Cats are afraid of dogs.

Mice are afraid of cats.

Gertrude is a sheep.

What is Gertrude afraid of? **A:wolves**

## Task 16: Basic Induction

Lily is a swan.

Lily is white.

Bernhard is green.

Greg is a swan.

What color is Greg? **A:white**

## Task 17: Positional Reasoning

The triangle is to the right of the blue square.

The red square is on top of the blue square.

The red sphere is to the right of the blue square.

Is the red sphere to the right of the blue square? **A:yes**

Is the red square to the left of the triangle? **A:yes**

## Task 18: Size Reasoning

The football fits in the suitcase.

The suitcase fits in the cupboard.

The box is smaller than the football.

Will the box fit in the suitcase? **A:yes**

Will the cupboard fit in the box? **A:no**

## Task 19: Path Finding

The kitchen is north of the hallway.

The bathroom is west of the bedroom.

The den is east of the hallway.

The office is south of the bedroom.

How do you go from den to kitchen? **A: west, north**

How do you go from office to bathroom? **A: north, west**

## Task 20: Agent's Motivations

John is hungry.

John goes to the kitchen.

John grabbed the apple there.

Daniel is hungry.

Where does Daniel go? **A:kitchen**

Why did John go to the kitchen? **A:hungry**

# Learning End-to-End Goal-Oriented Dialog

# Facebook bAbI Dialogue Datasets

1 hi      hello what can i help you with today

2 can you make a restaurant reservation with italian cuisine for six people in a  
cheap price range                      i'm on it

3 <SILENCE>      where should it be

4 rome please      ok let me look into some options for you

5 <SILENCE>      api\_call italian rome six cheap



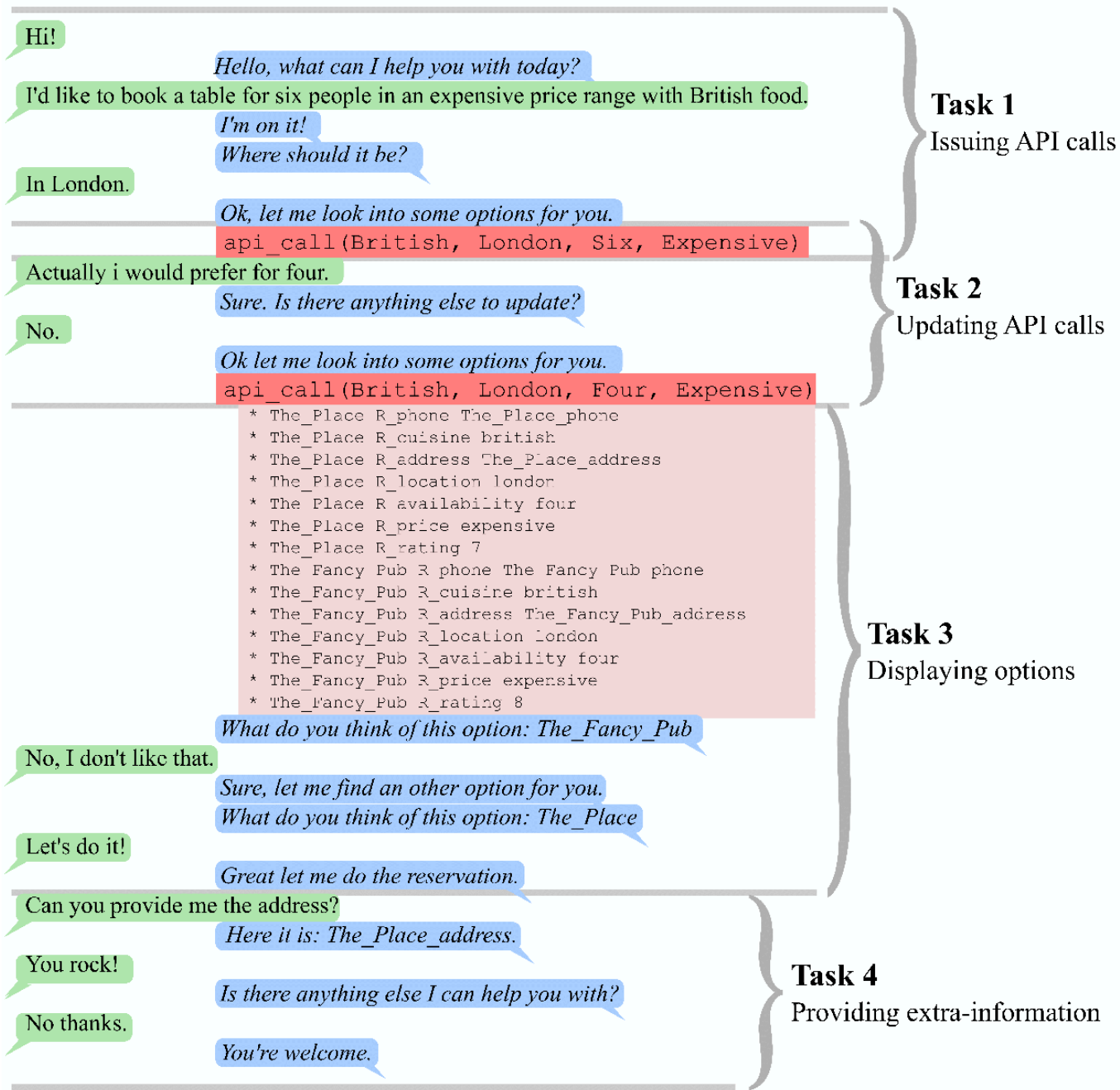

**Task 5** Conducting full dialogs

# The Dialog bAbI Tasks

Hi!

*Hello, what can I help you with today?*

I'd like to book a table for six people in an expensive price range with British food.

*I'm on it!*

*Where should it be?*

In London.

*Ok, let me look into some options for you.*

```
api_call(British, London, Six, Expensive)
```

Actually i would prefer for four.

*Sure. Is there anything else to update?*

No.

*Ok let me look into some options for you.*

```
api_call(British, London, Four, Expensive)
```

**Task 1**

Issuing API calls

**Task 2**

Updating API calls

# The Dialog bAbI Tasks

```
* The_Place R_phone The_Place_phone
* The_Place R_cuisine british
* The_Place R_address The_Place_address
* The_Place R_location london
* The_Place R_availability four
* The_Place R_price expensive
* The_Place R_rating 7
* The_Fancy_Pub R_phone The_Fancy_Pub_phone
* The_Fancy_Pub R_cuisine british
* The_Fancy_Pub R_address The_Fancy_Pub_address
* The_Fancy_Pub R_location london
* The_Fancy_Pub R_availability four
* The_Fancy_Pub R_price expensive
* The_Fancy_Pub R_rating 8
```

**Task 3**  
Displaying options

*What do you think of this option: The\_Fancy\_Pub*

No, I don't like that.

*Sure, let me find an other option for you.*

*What do you think of this option: The\_Place*

Let's do it!

*Great let me do the reservation.*

# The Dialog bAbI Tasks

*What do you think of this option: The\_Fancy\_Pub*

No, I don't like that.

*Sure, let me find an other option for you.*

*What do you think of this option: The\_Place*

Let's do it!

*Great let me do the reservation.*

Can you provide me the address?

*Here it is: The\_Place\_address.*

You rock!

*Is there anything else I can help you with?*

No thanks.

*You're welcome.*

**Task 4**  
Providing extra-information

**Task 5** Conducting full dialogs

# References

- Paolo Sironi (2016), “FinTech Innovation: From Robo-Advisors to Goal Based Investing and Gamification”, Wiley.
- Min-Yuh Day, Cheng-Chia Tsai, Wei-Chun Chuang, Jin-Kun Lin, Hsiu-Yuan Chang, Tzu-Jui Sun, Yuan-Jie Tsai, Yi-Heng Chiang, Cheng-Zhi Han, Wei-Ming Chen, Yun-Da Tsai, Yi-Jing Lin, Yue-Da Lin, Yu-Ming Guo, Ching-Yuan Chien, and Cheng-Hung Lee (2016), "IMTKU Question Answering System for World History Exams at NTCIR-12 QA Lab2", The 12th NTCIR Conference on Evaluation of Information Access Technologies (NTCIR-12), Tokyo, Japan, June 7-10, 2016, pp.425-431
- Yun-Nung Chen, Dilek Hakkani-Tür, Gokhan Tur, Jianfeng Gao, and Li Deng (2016), "End-to-end memory networks with knowledge carryover for multi-turn spoken language understanding." In Proceedings of Interspeech.
- Hakkani-Tür, Dilek, Gokhan Tur, Asli Celikyilmaz, Yun-Nung Chen, Jianfeng Gao, Li Deng, and Ye-Yi Wang. "Multi-domain joint semantic frame parsing using bi-directional RNN-LSTM." In Proceedings of The 17th Annual Meeting of the International Speech Communication Association. 2016.
- Jeongkyu Shin (2016), Building AI Chat bot with Python 3 and TensorFlow, PyCon APAC 2016.
- Ankit Kumar, Ozan Irsoy, Jonathan Su, James Bradbury, Robert English, Brian Pierce, Peter Ondruska, Ishaan Gulrajani, and Richard Socher (2015). "Ask me anything: Dynamic memory networks for natural language processing." arXiv preprint arXiv:1506.07285.
- Antoine Bordes and Jason Weston (2016), "Learning End-to-End Goal-Oriented Dialog." *arXiv preprint arXiv:1605.07683*.
- Jason Weston, Antoine Bordes, Sumit Chopra, Alexander M. Rush, Bart van Merriënboer, Armand Joulin, and Tomas Mikolov (2015), "Towards AI-complete question answering: A set of prerequisite toy tasks." arXiv preprint arXiv:1502.05698.