

# Case Study for Information Management

## 資訊管理個案

### E-commerce: Digital Markets, Digital Goods

### Amazon vs. Walmart

### (Chap. 10)

1021CSIM4B10

TLMXB4B (M1824)

Tue 2, 3, 4 (9:10-12:00) B502

Min-Yuh Day

戴敏育

Assistant Professor

專任助理教授

Dept. of Information Management, Tamkang University

淡江大學 資訊管理學系

<http://mail.tku.edu.tw/myday/>

2013-12-03

# 課程大綱 (Syllabus)

週次	日期	內容 (Subject/Topics)
1	102/09/17	Introduction to Case Study for Information Management
2	102/09/24	Information Systems in Global Business: UPS (Chap. 1)
3	102/10/01	Global E-Business and Collaboration: NTUC Income (Chap. 2)
4	102/10/08	Information Systems, Organization, and Strategy: iPad and Apple (Chap. 3)
5	102/10/15	IT Infrastructure and Emerging Technologies: Salesforce.com (Chap. 5)
6	102/10/22	Foundations of Business Intelligence: Lego (Chap. 6)

# 課程大綱 (Syllabus)

週次	日期	內容 (Subject/Topics)
7	102/10/29	Telecommunications, the Internet, and Wireless Technology: Google, Apple, and Microsoft (Chap. 7)
8	102/11/05	Securing Information System: Facebook (Chap. 8)
9	102/11/12	Midterm Report (期中報告)
10	102/11/19	期中考試週
11	102/11/26	Enterprise Application: Border States Industries Inc. (BSE) (Chap. 9)
12	102/12/03	E-commerce: Amazon vs. Walmart (Chap. 10)

# 課程大綱 (Syllabus)

週次	日期	內容 (Subject/Topics)
13	102/12/10	Knowledge Management: Tata Consulting Services (Chap. 11) [Invited Talk]
14	102/12/17	Enhancing Decision Making: CompStat (Chap. 12)
15	102/12/24	Building Information Systems: Electronic Medical Records (Chap. 13)
16	102/12/31	Managing Projects: JetBlue and WestJet (Chap. 14)
17	103/01/07	Final Report (期末報告)
18	103/01/14	期末考試週

**Chap. 10**  
**E-commerce:**  
**Digital Markets,**  
**Digital Goods –**  
**Amazon vs. Walmart**

# Amazon vs. Walmart:

## Which Giant Will Dominate E-commerce? (Chap. 10) (pp. 436-438)

1. What concepts in the chapter are illustrated in this case?
2. Analyze Amazon and Walmart.com using the value chain and competitive forces models.
3. What are the management, organization, and technology factors that have contributed to the success of both Wal-Mart and Amazon?
4. Compare Wal-Mart's and Amazon's e-commerce business models. Which is stronger? Explain your answer.
5. Where would you prefer to make your Internet purchases? Amazon or Walmart.com? Why?

# Overview of Fundamental MIS Concepts

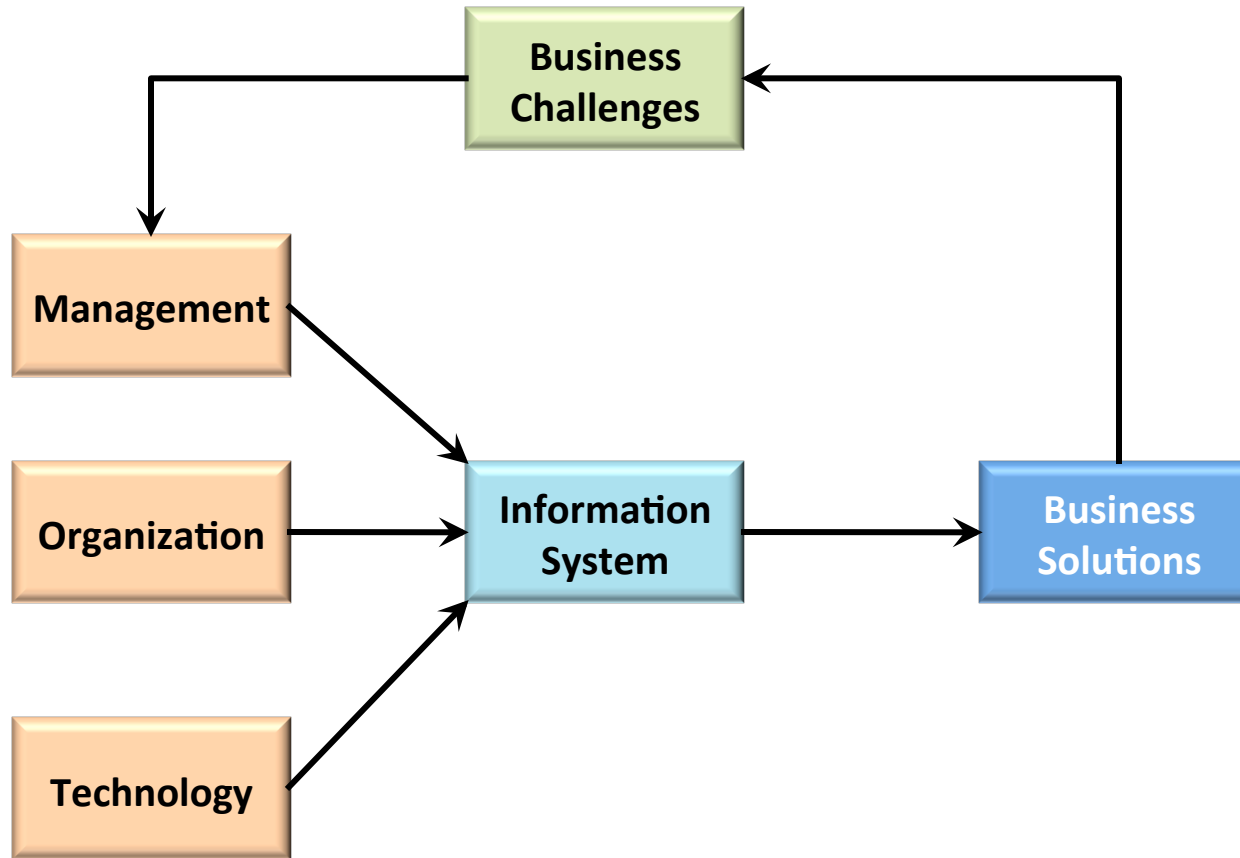

# THE GROWTH OF E-COMMERCE

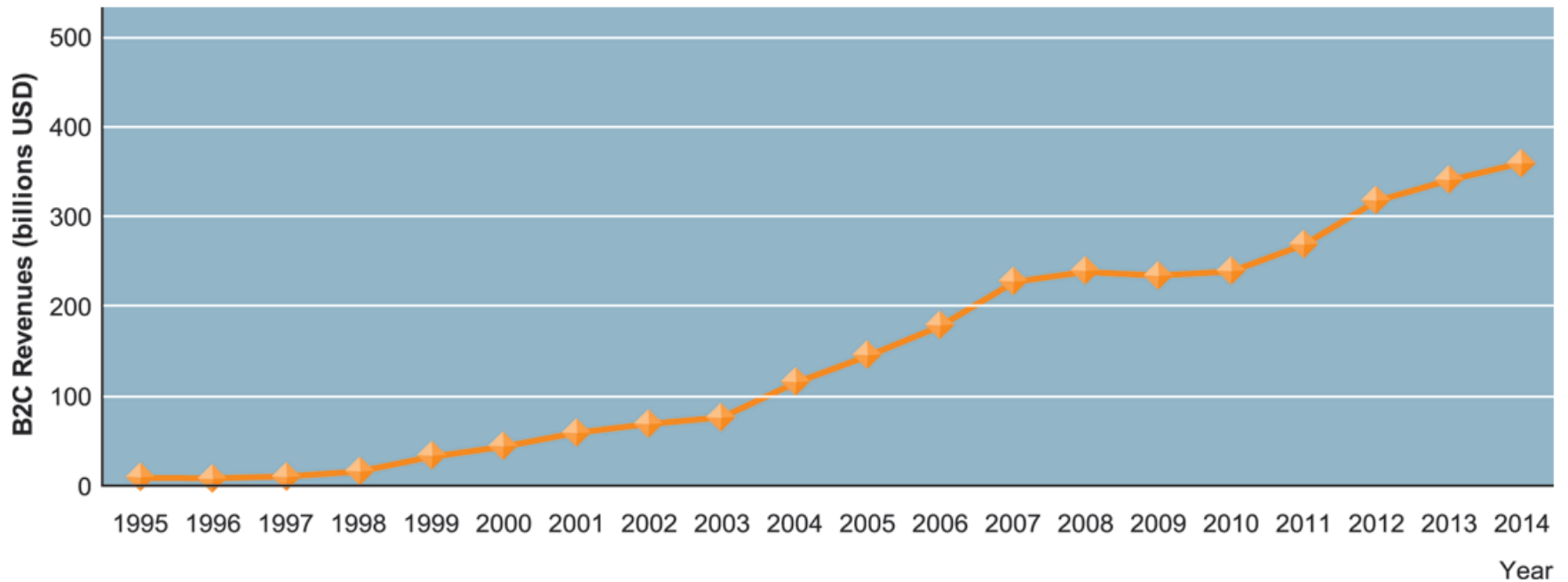



# 8 Unique Features of E-commerce

1. Ubiquity
2. Global reach
3. Universal standards
4. Richness
5. Interactivity
6. Information density
7. Personalization/Customization
8. Social technology

# Key concepts in e-commerce

- Digital markets reduce
  - Information asymmetry
  - Search costs
  - Transaction costs
  - Menu costs
- Digital markets enable
  - Price discrimination
  - Dynamic pricing
  - Disintermediation

# Key concepts in e-commerce

- Digital goods
  - Goods that can be delivered over a digital network
    - E.g. Music tracks, video, software, newspapers, books
  - Cost of producing first unit almost entire cost of product: marginal cost of 2nd unit is about zero
  - Costs of delivery over the Internet very low
  - Marketing costs remain the same; pricing highly variable
  - Industries with digital goods are undergoing revolutionary changes (publishers, record labels, etc.)

# THE BENEFITS OF DISINTERMEDIATION TO THE CONSUMER

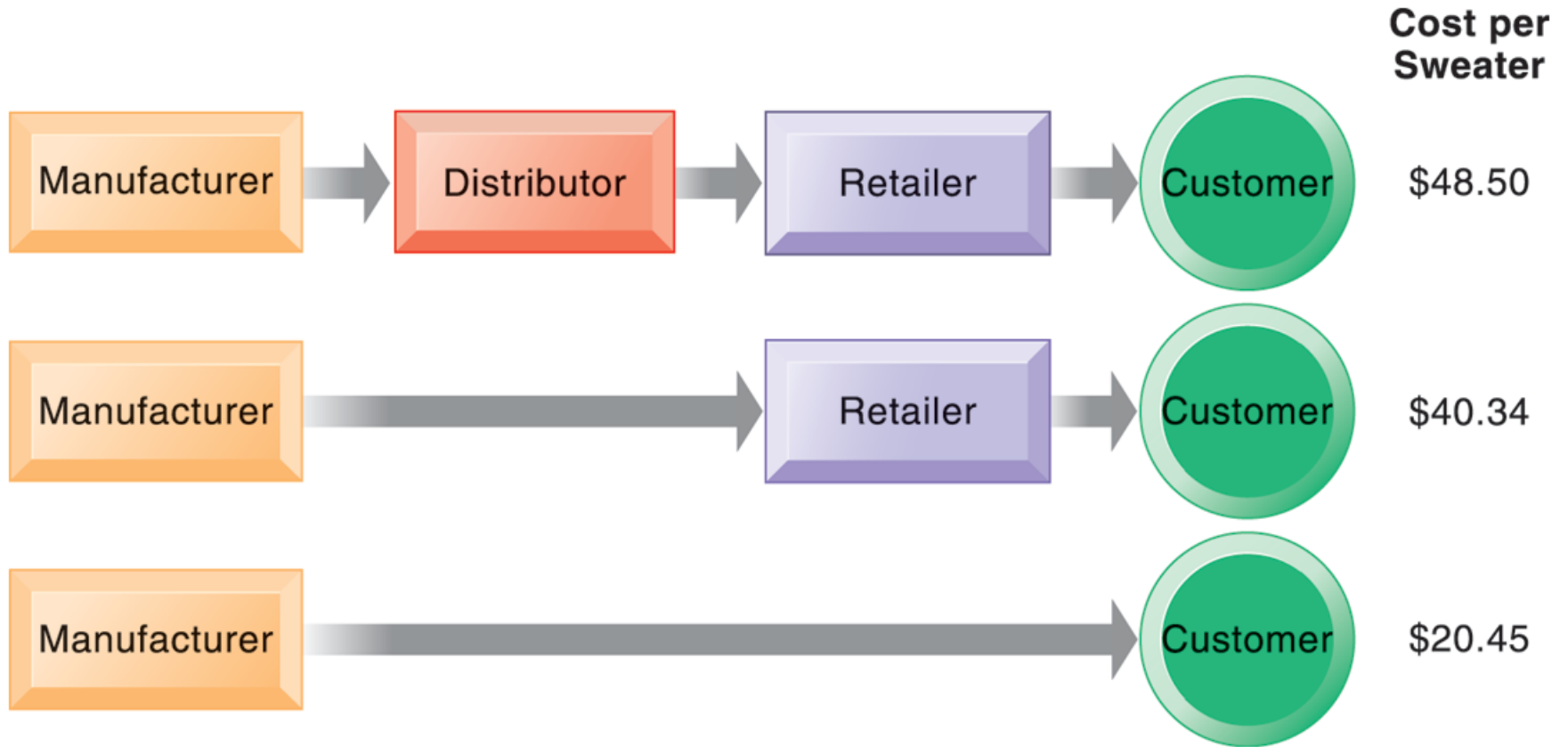

# Types of E-commerce

1. Business-to-consumer (B2C)
2. Business-to-business (B2B)
3. Consumer-to-consumer (C2C)
4. Mobile commerce (m-commerce)

# E-commerce

## Business Models

1. Portal
2. E-tailer
3. Content Provider
4. Transaction Broker
5. Market Creator
6. Service Provider
7. Community Provider

# E-commerce

## Revenue Models

1. Advertising
2. Sales
3. Subscription
4. Free/Freemium
5. Transaction Fee
6. Affiliate

# Understanding **Business Model**

- **Business Model**
- Revenue Model
- Business Strategy
- Business Strategy and Information System Alignment



# Business Model

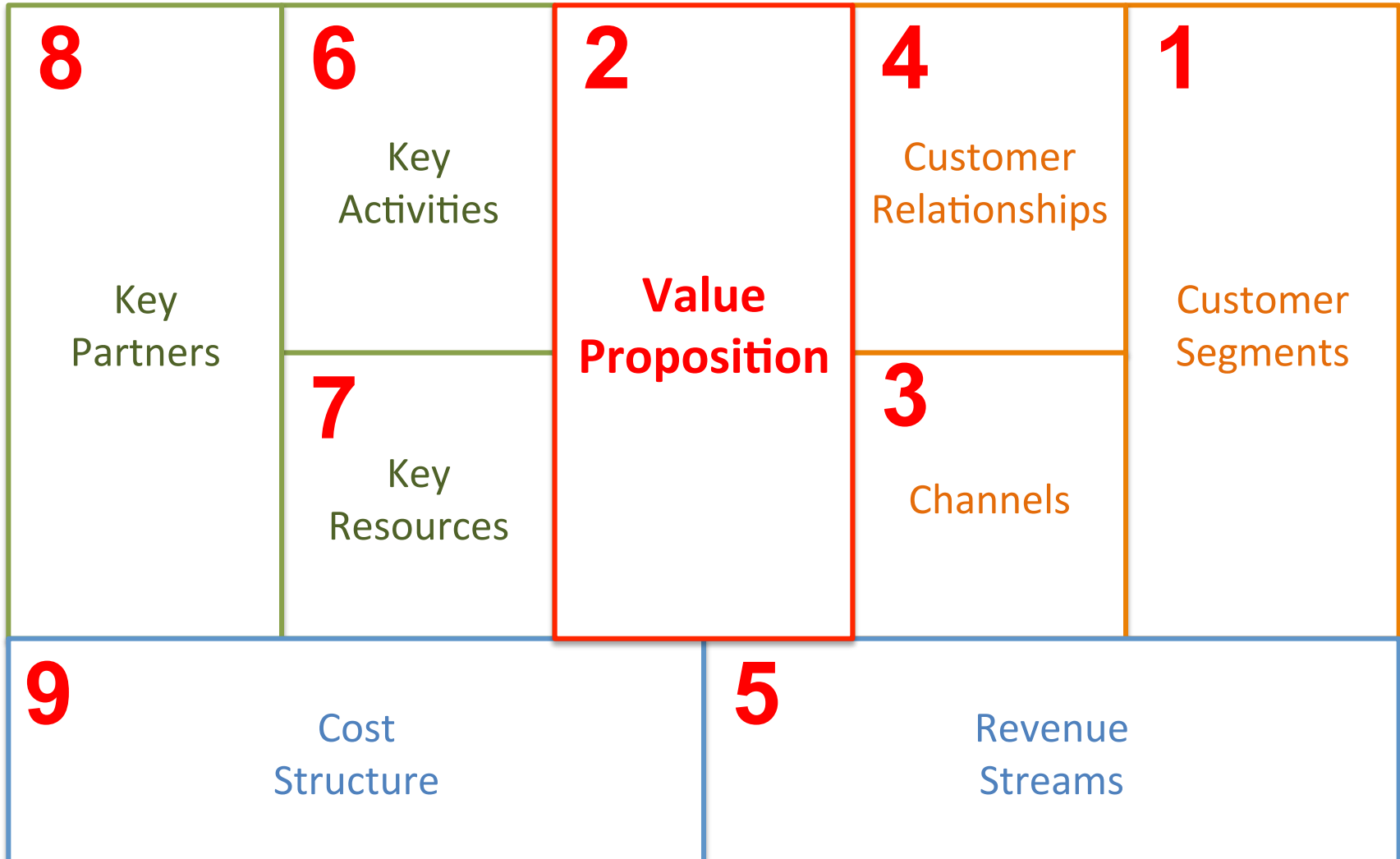

# Business

- “the activity of providing goods and services involving financial, commercial and industrial aspects.” (WordNet 2.0)

# Model

- “a simplified description and representation of a complex entity or process.” (WordNet 2.0)

# Business Model

- A business model is a **conceptual tool** containing a set of **objects, concepts and their relationships** with the objective to express the **business logic** of a specific firm.
- Therefore we must consider which **concepts and relationships** allow a simplified description and representation of **what value is provided to customers, how this is done** and with which **financial consequences**.

# Occurrences of the Term "Business Model" in Scholarly Reviewed Journals

<b>Year</b>	<b>In Title</b>	<b>In Abstract</b>	<b>In Keywords</b>	<b>in Full Text</b>
2003	30	159	10	667
2002	22	109	2	617
2001	11	100	7	609
2000	16	67	1	491
1999	3	42	1	262
1998	1	19	0	128
1997	1	14	0	66
1996	0	14	0	57
1995	0	4	0	36
1994	0	2	0	18
1993	0	5	0	18
1992	0	2	0	15
1991	0	1	0	10
1990	0	4	0	7

# Business Model Concept Hierarchy

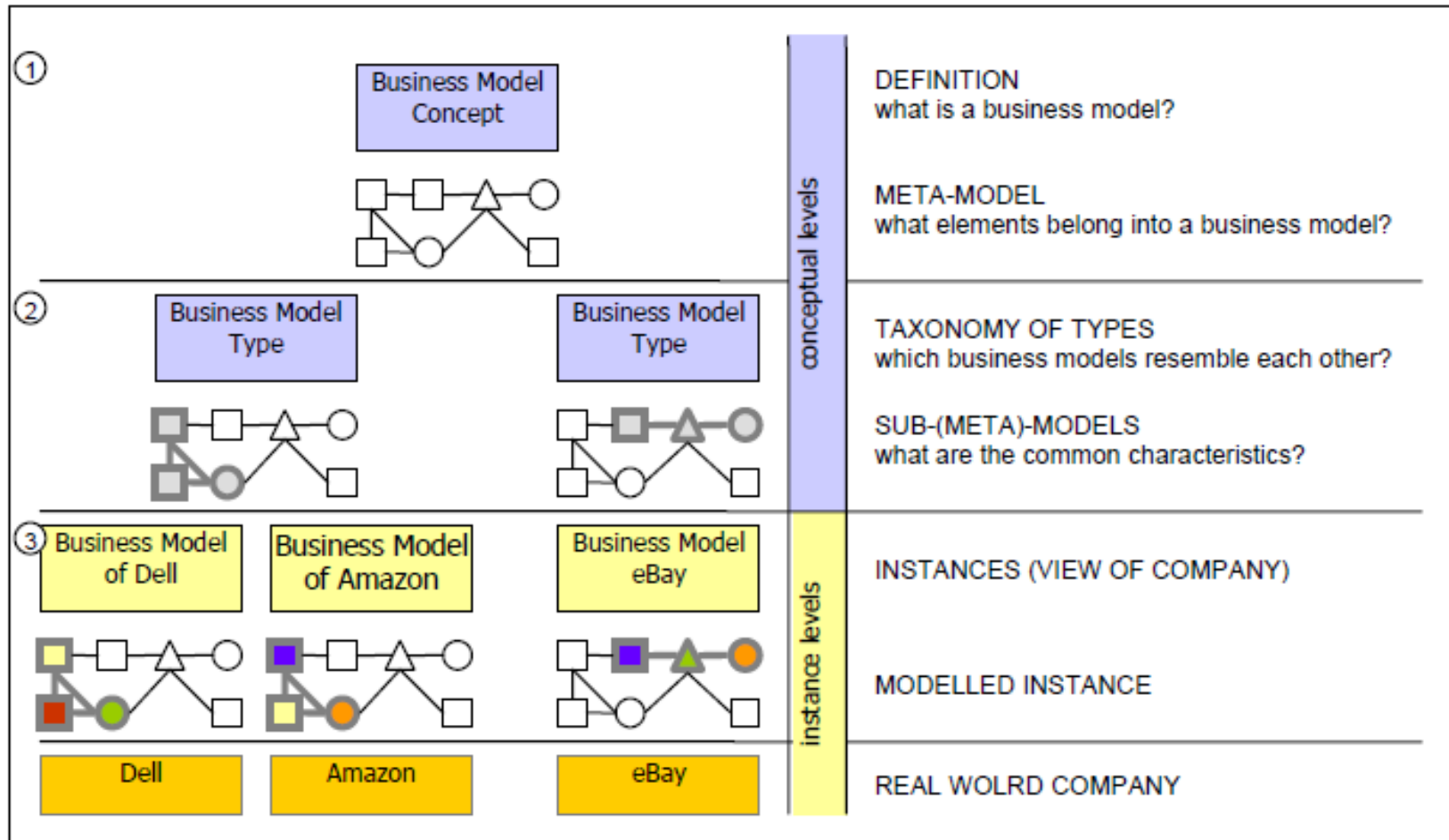

# EVOLUTION OF THE BUSINESS MODEL CONCEPT

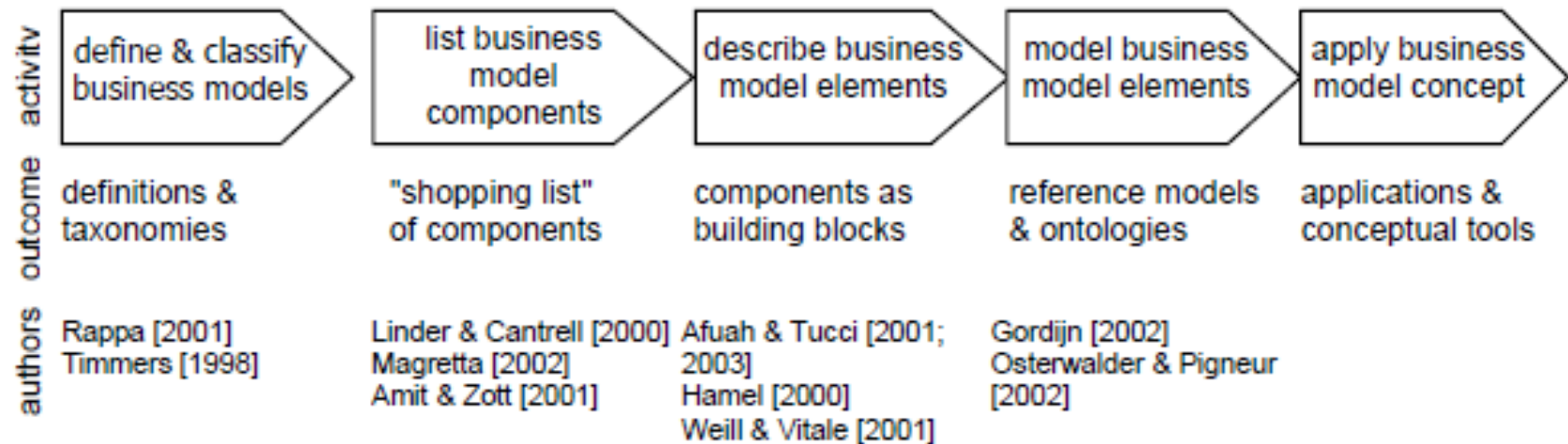

# Business Model vs. Business Process Model

- Business Model
  - a view of the firm's logic for creating and commercializing value
- Business process model
  - how a business case is implemented in processes



# Business Model vs. Strategy

- Business Models
  - a system that shows how the pieces of a business fit together.
  - an abstraction of a firm's strategy
- Strategy
  - includes competition

# Implementing Business Models

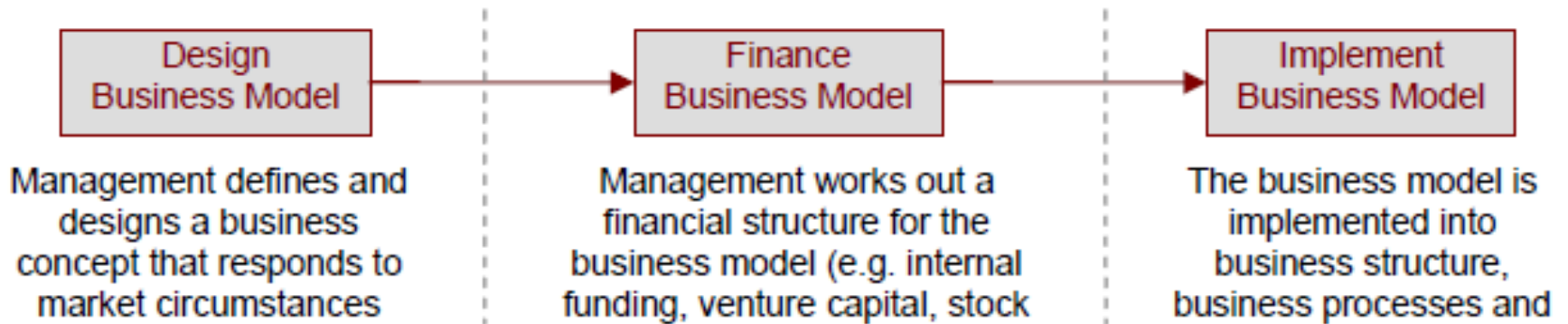

# The Business Model's Place in the Firm

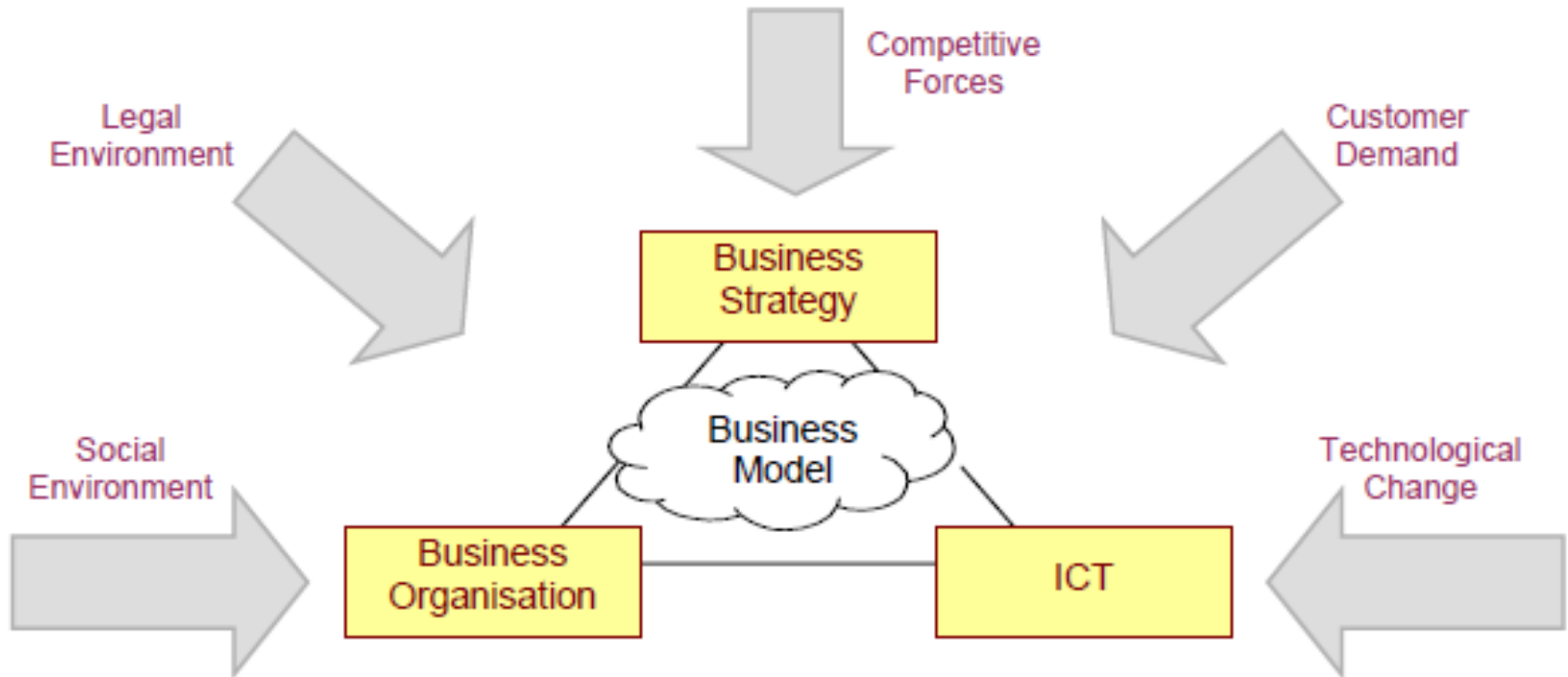

# Nine Business Model Building Blocks

Pillar	Business Model Building Block	Description
Product	Value Proposition	Gives an overall view of a company's bundle of products and services.
Customer Interface	Target Customer	Describes the segments of customers a company wants to offer value to.
	Distribution Channel	Describes the various means of the company to get in touch with its customers.
	Relationship	Explains the kind of links a company establishes between itself and its different customer segments.
Infrastructure Management	Value Configuration	Describes the arrangement of activities and resources.
	Core Competency	Outlines the competencies necessary to execute the company's business model.
	Partner Network	Portrays the network of cooperative agreements with other companies necessary to efficiently offer and commercialize value.
Financial Aspects	Cost Structure	Sums up the monetary consequences of the means employed in the business model.
	Revenue Model	Describes the way a company makes money through a variety of revenue flows.

# Domains Addressed in Business Models

Business model ontology	Stähler 2001	Weill and Vitale 2001	Petrovic, Kittl et al.	Gordijn 2002	Afuah and Tucci 2003	Tapscott, Ticoll et al. 2000	Linder and Cantrell 2000
Value Proposition	value proposition	Value Proposition, strategic objective	Value Model	Value offering	Customer Value		value proposition
Target Customer		Customer Segments		Market Segment	Scope		
Distribution Channel		Channels	Customer relations model				channel model
Customer Relationship			Customer relations model				commerce relationship
Value Configuration	Architecture		Production Mode	e3-value configuration	connected activities, value configuration	b-webs	commerce process model
Capability		Core competencies, CSF	Resource Model		capabilities		
Partnership	Architecture	e-business schematics		Actors	sustainability (team-up strategy)	b-webs	
Cost Structure				Value exchange	cost structure		
Revenue Model	Revenue Model	Source of revenue	Revenue Model	value exchange	pricing, revenue source		pricing model, revenue model

# Domains Addressed in Business Models (cont.)

Business model ontology	Hamel 2000	Mahadevan 2000	Chesbrough and Rosenbloom 2000	Magretta 2002	Amit and Zott 2001	Applegate and Collura 2001	Maitland and Van de Kar 2002
Value Proposition	Product/market scope	Value stream	Value proposition	What does the customer value?	Transaction component	Product and Services offered	Value proposition, assumed value
Target Customer	Market scope		Market segment	Who is the customer?		Market opportunity	Market segment
Distribution Channel	Fulfillment & support, info & insight			How can we deliver value at an appropriate cost?		Marketing/sales model	
Customer Relationship	Relationship dynamics					Brand and reputation	
Value Configuration	Core processes	Logistical stream	Structure of the value chain		Architectural configuration	Operating model	
Capability	core competencies, strategic assets					Organization and culture, management model)	
Partnership	suppliers, partners, coalitions		Position in the value chain		Transaction component	Partners	Companies involved in creating value
Cost Structure			Cost structure	What is the underlying economic vale?			
Revenue Model	pricing structure	Revenue stream		How do we make money in this business		Benefits to firm and stakeholders	Revenue Model

# Planning, Changing and Implementing Business Models

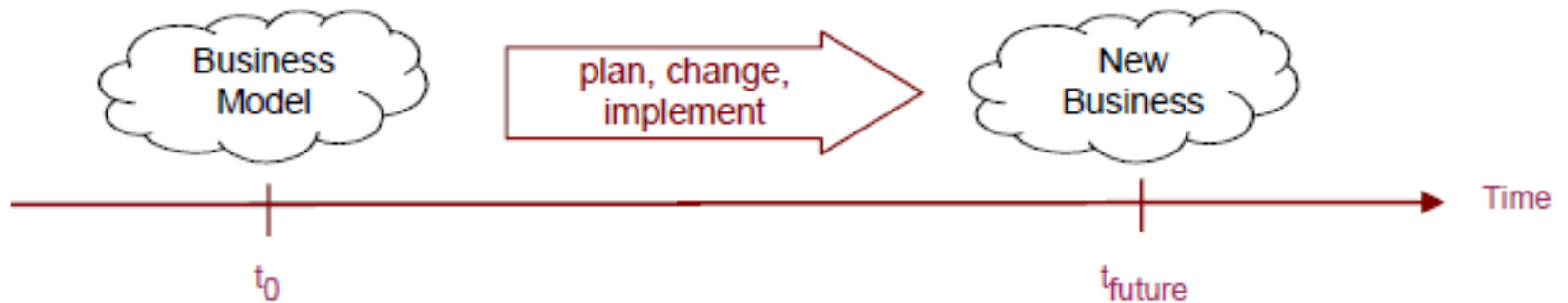

The management analyzes the current business model's adequacy to environmental pressures and designs a new business model

The new business model becomes a goal to achieve and guides planning, change and implementation

# Business Strategy and Information Systems Alignment

Managers are aware of the use of Information Systems to realize goals, exploit opportunities and obtain competitive advantage

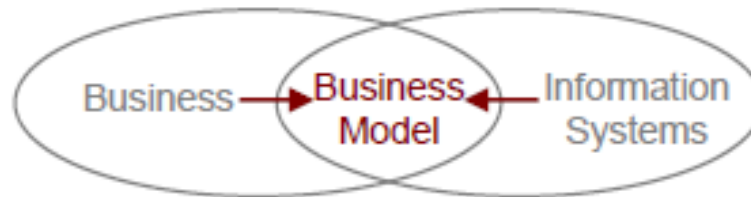

Information Systems support the company's business model and are targeted on areas that are critical to successful business performance



# Business and IT/IS Alignment

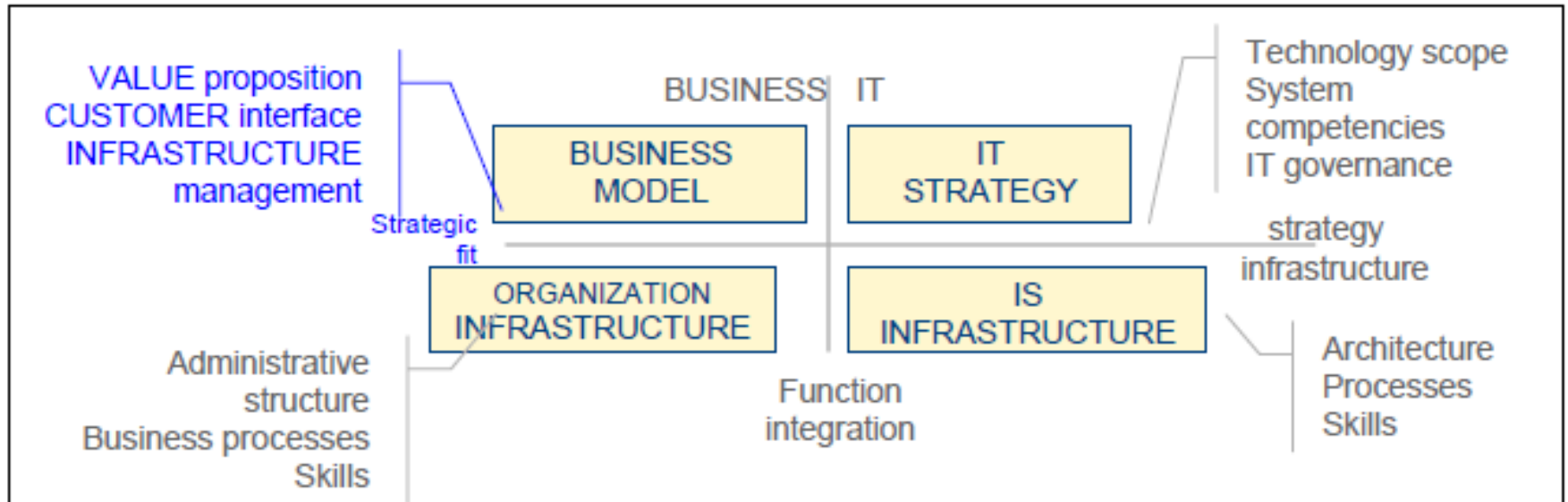

Adapted from [Henderson and Venkatraman 1999]

# Definition of Business Model

**A business model**  
**describes the rationale of**  
**how an organization**  
**creates, delivers, and captures**  
**value.**

# Business Model Canvas

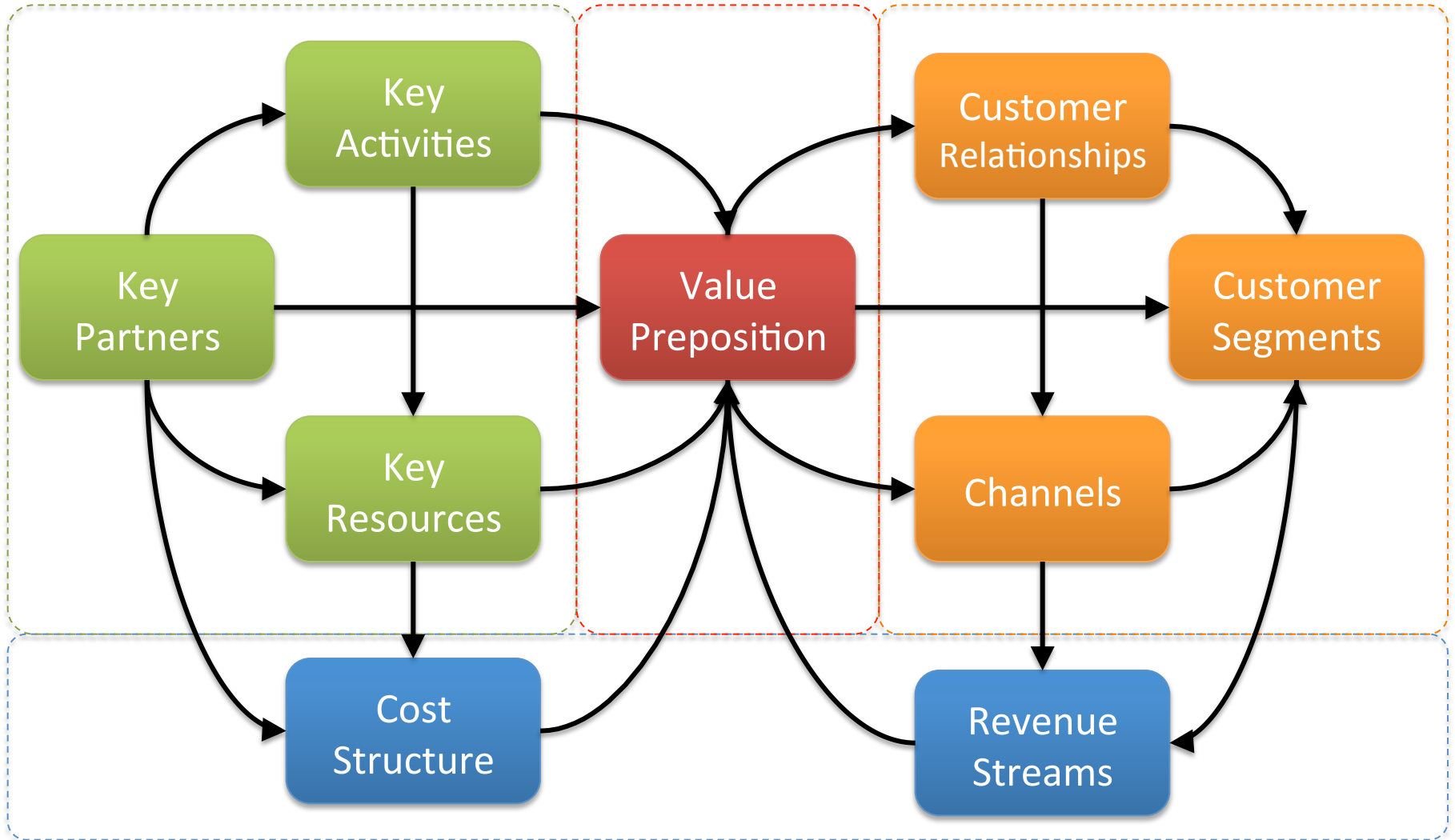
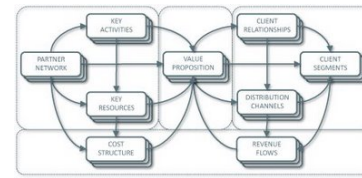

Source: [http://nonlinearthinking.typepad.com/nonlinear\\_thinking/2008/07/the-business-model-canvas.html](http://nonlinearthinking.typepad.com/nonlinear_thinking/2008/07/the-business-model-canvas.html)  
<https://www.youtube.com/watch?v=QoAOzMTLP5s>

# The 9 Building Blocks of Business Model

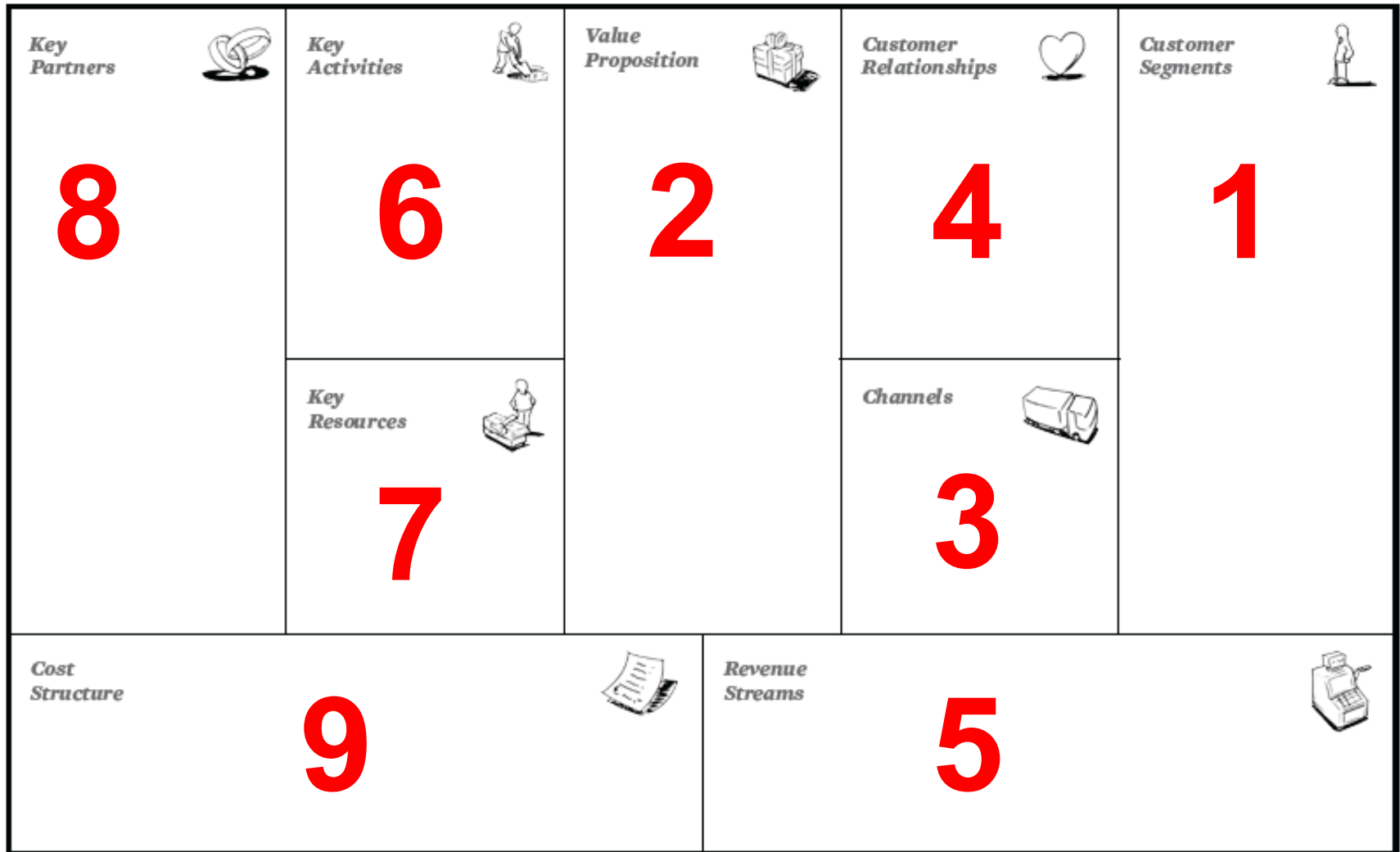



# 1. Customer Segments

Defines the different groups of people or organizations an enterprise aims to reach and serve

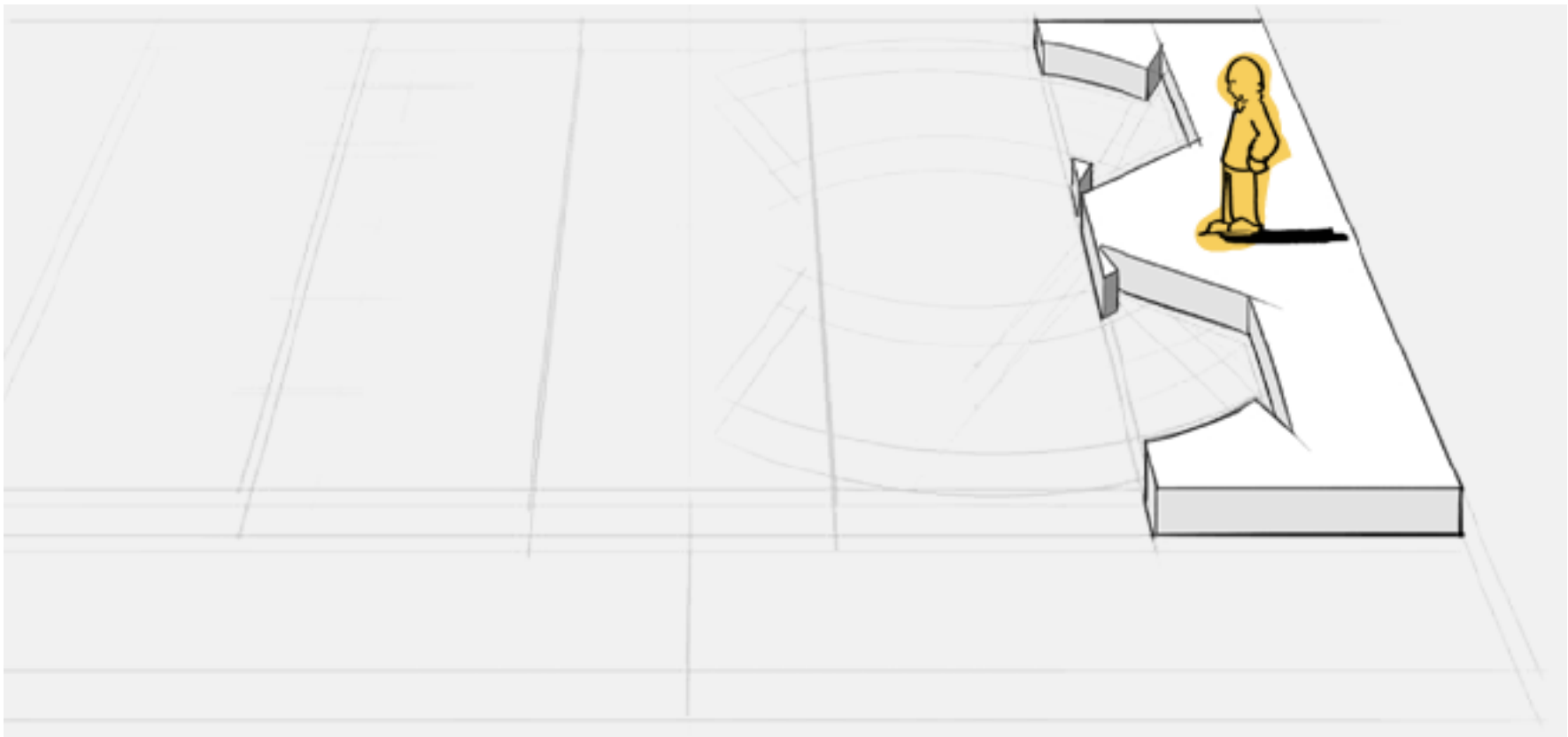

## 2. Value Propositions

Describes the bundle of products and services that create value for a specific Customer Segment



# 3. Channels

Describes how a company communicates with and reaches its Customer Segments to deliver a Value Proposition

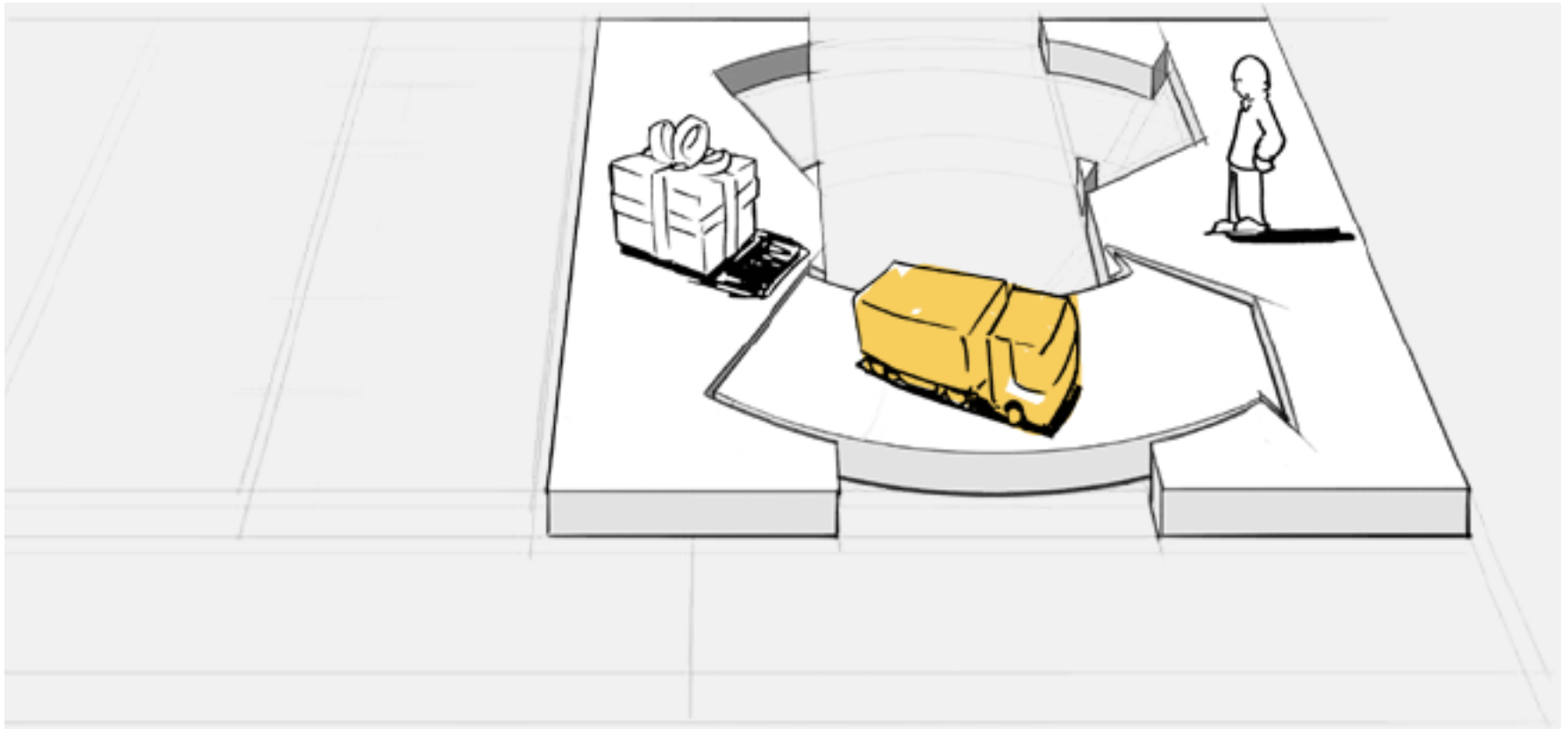



# 4. Customer Relationships

Describes the types of relationships a company establishes with specific Customer Segments

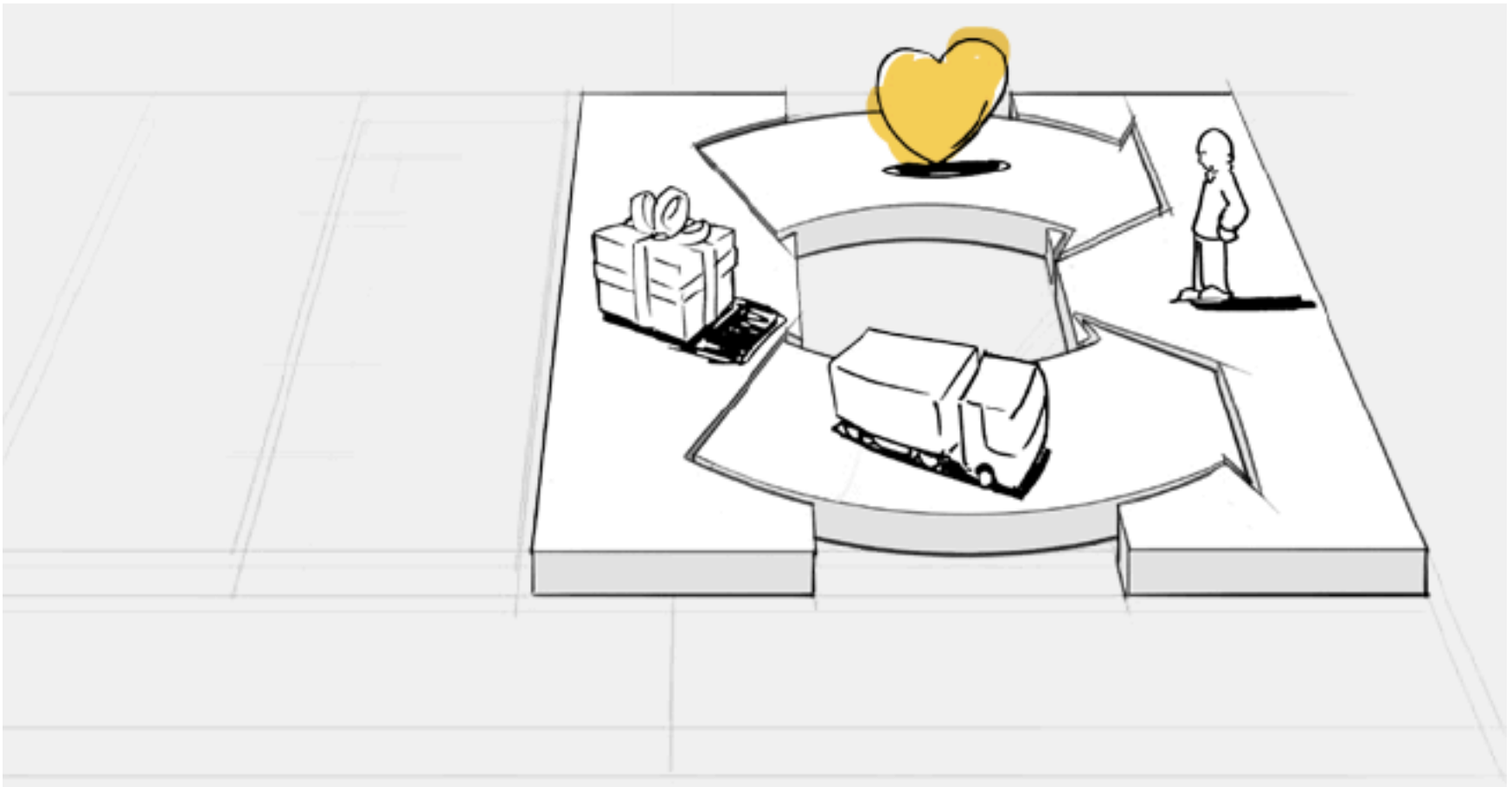

# 5. Revenue Streams

Represents the cash a company generates from each Customer Segment (costs must be subtracted from revenues to create earnings)

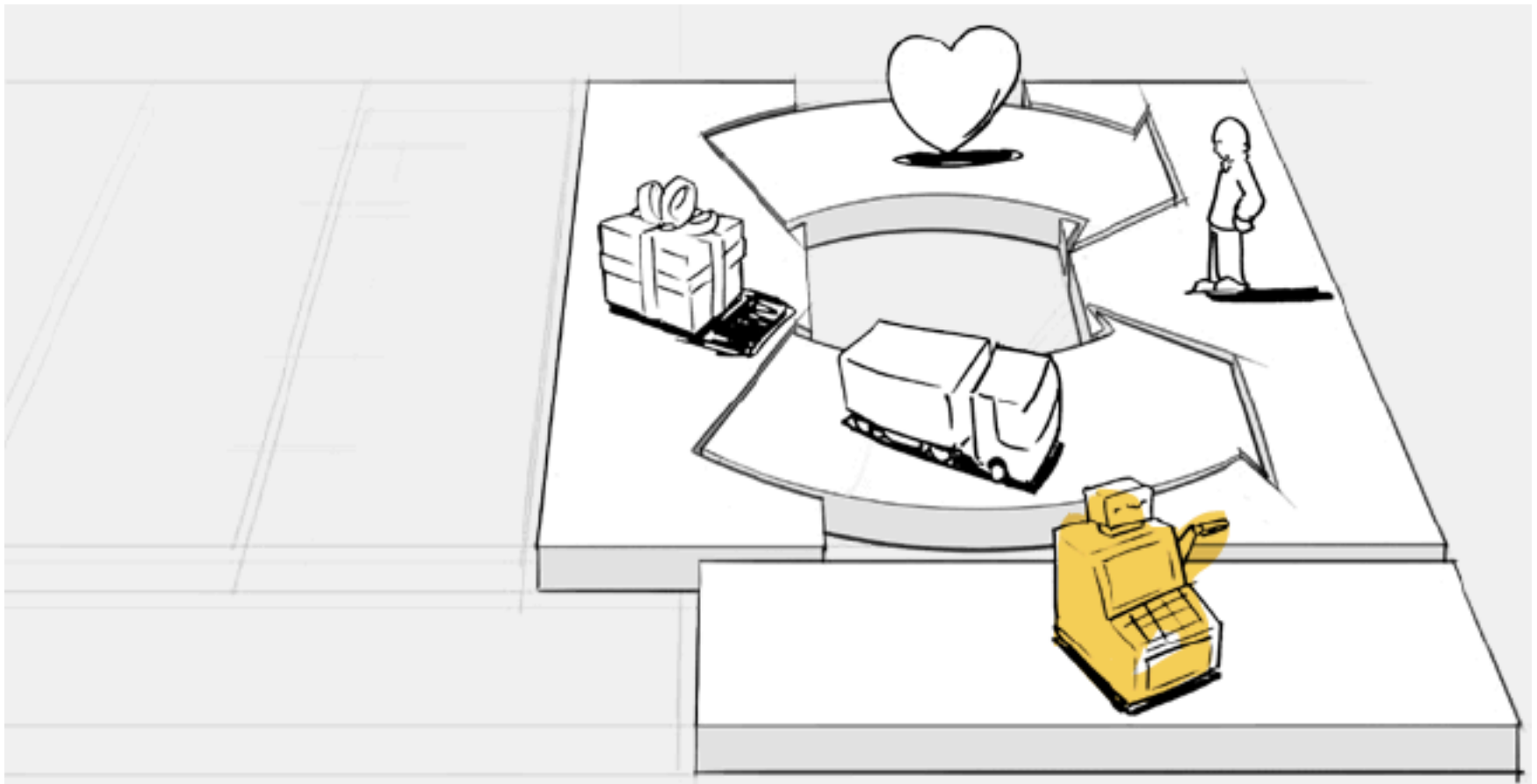

# 6. Key Resources

Describes the most important assets required to make a business model work

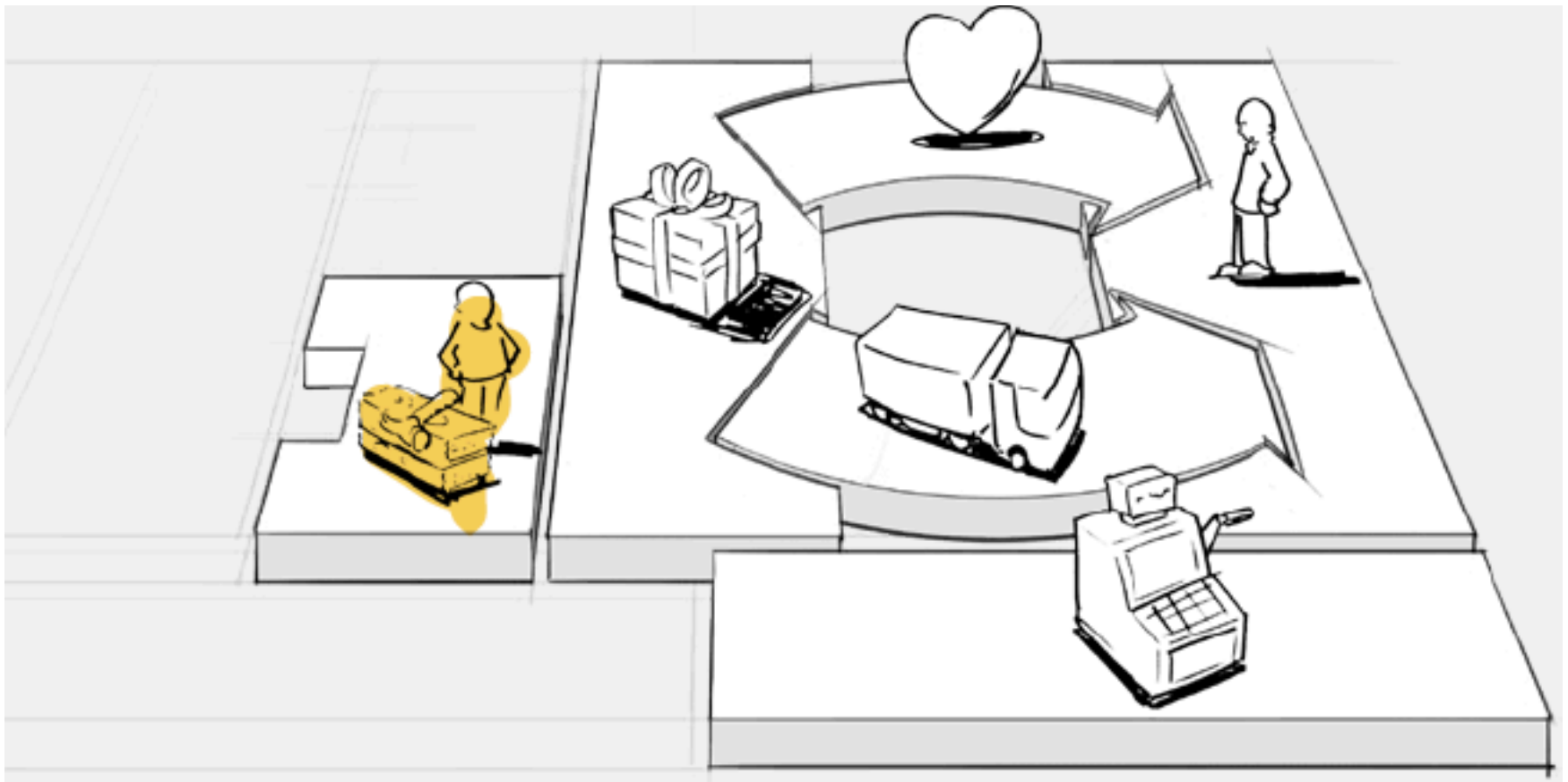

# 7. Key Activities

Describes the most important things a company must do to make its business model work

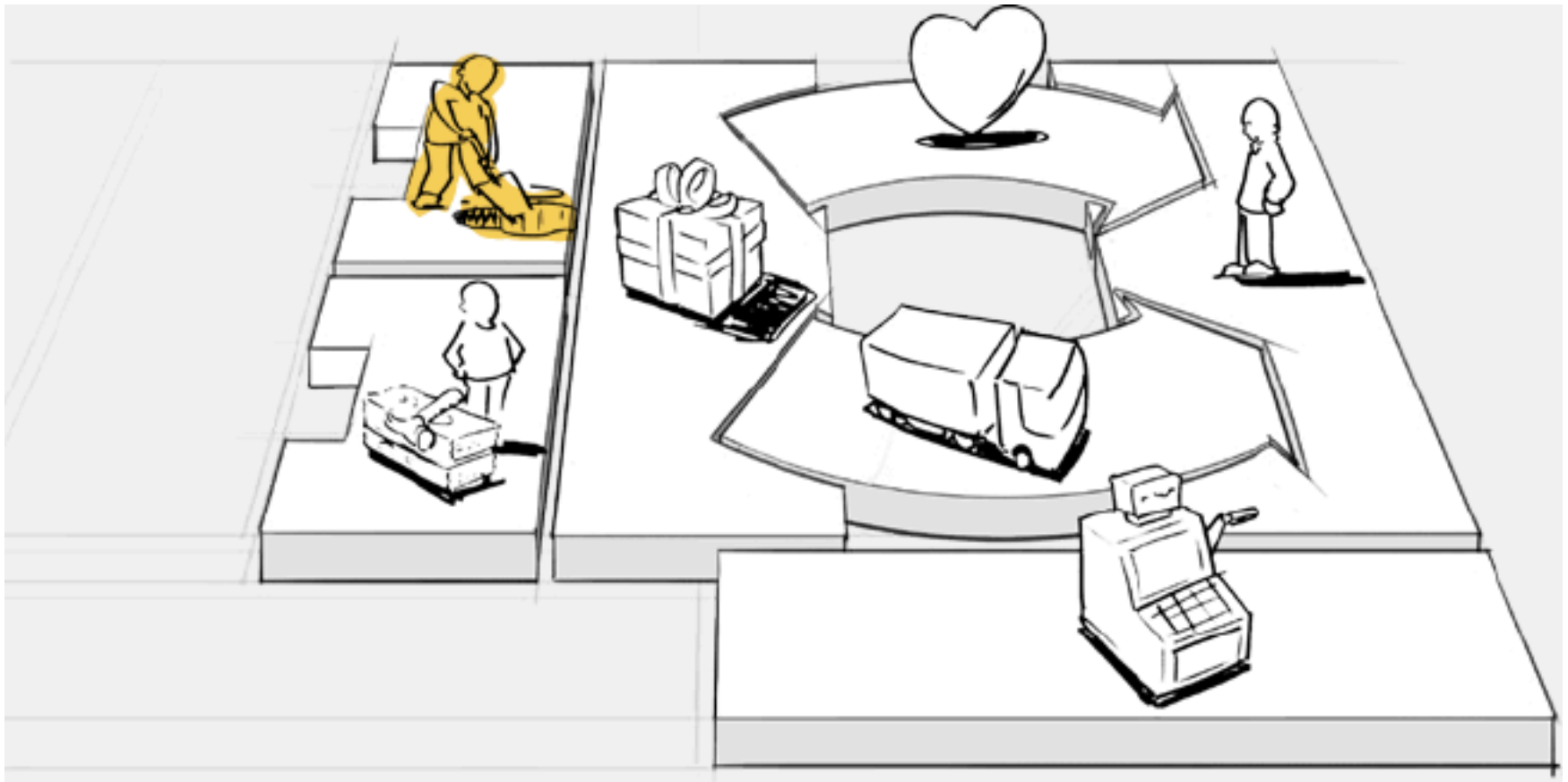

# 8. Key Partnerships

Describes the network of suppliers and partners that make the business model work

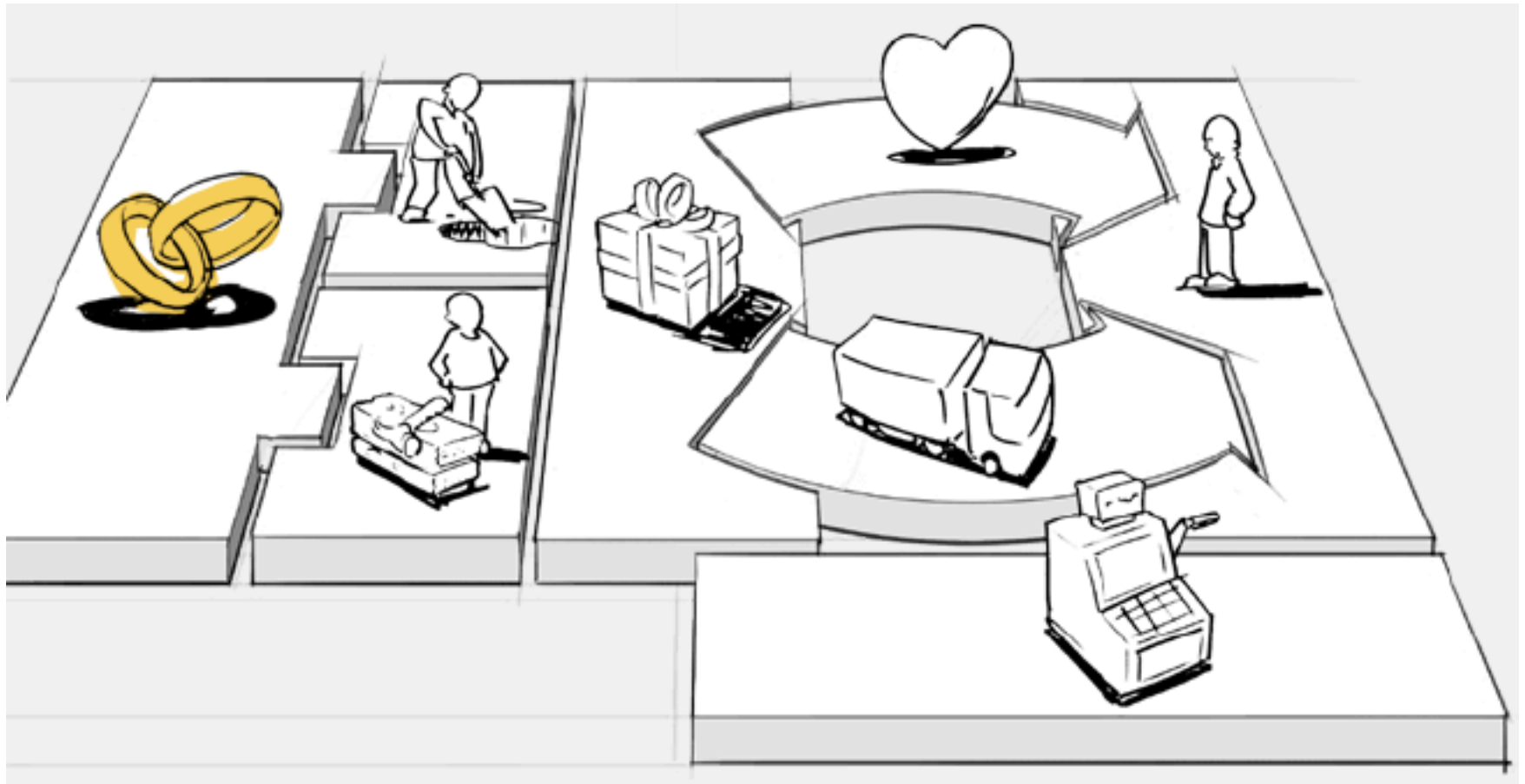

# 9. Cost Structure

Describes all costs incurred to operate a business model

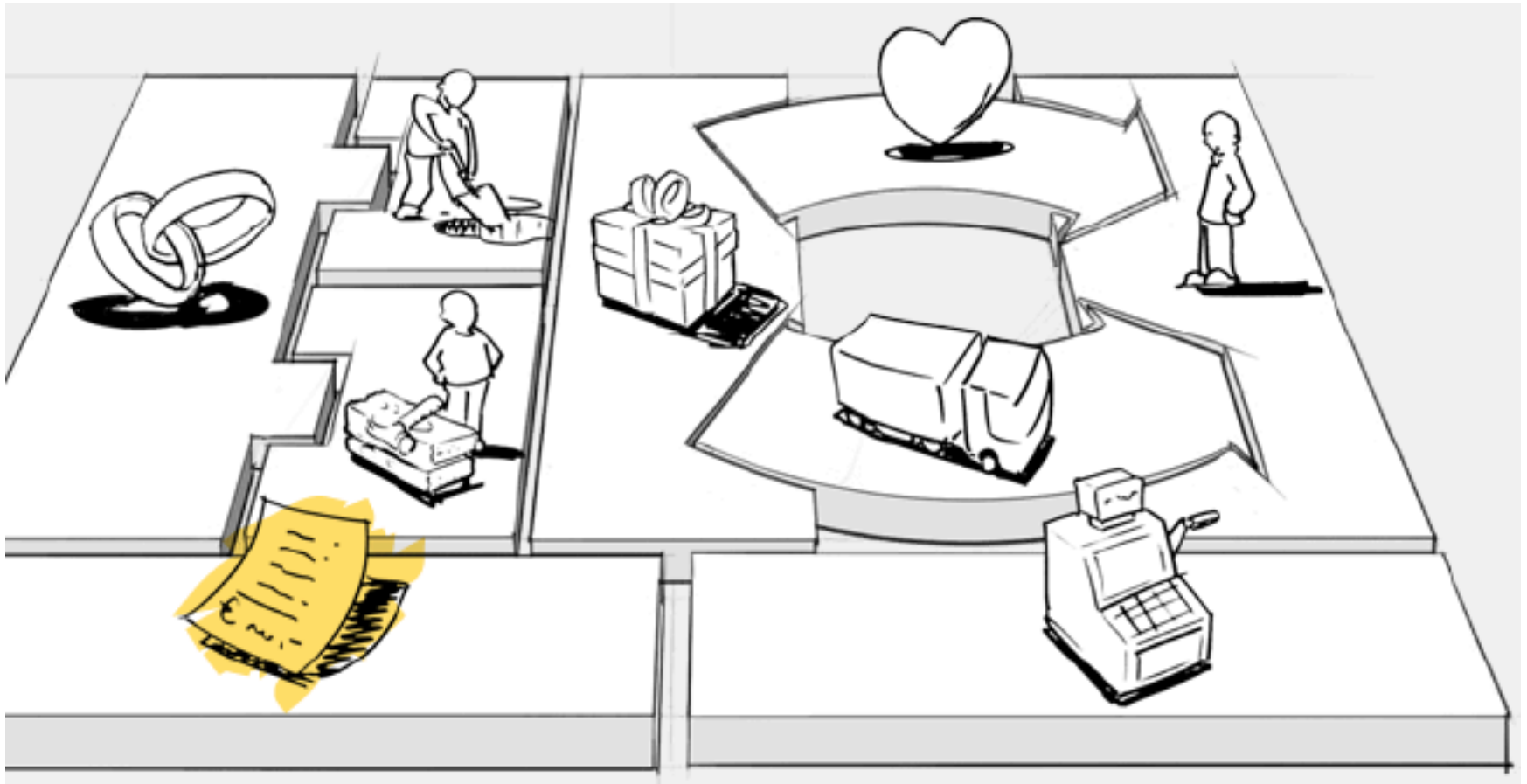

# The 9 Building Blocks of Business Model

## 1. Customer Segments

- An organization serves one or several Customer Segments.

## 2. Value Propositions

- It seeks to solve customer problems and satisfy customer needs with value propositions.

## 3. Channels

- Value propositions are delivered to customers through communication, distribution, and sales Channels.

## 4. Customer Relationships

- Customer relationships are established and maintained with each Customer Segment.

# The 9 Building Blocks of Business Model

## 5. Revenue Streams

- Revenue streams result from value propositions successfully offered to customers.

## 6. Key Resources

- Key resources are the assets required to offer and deliver the previously described elements...

## 7. Key Activities

- ...by performing a number of Key Activities.

## 8. Key Partnerships

- Some activities are outsourced and some resources are acquired outside the enterprise.

## 9. Cost Structure

- The business model elements result in the cost structure.



# Business Model

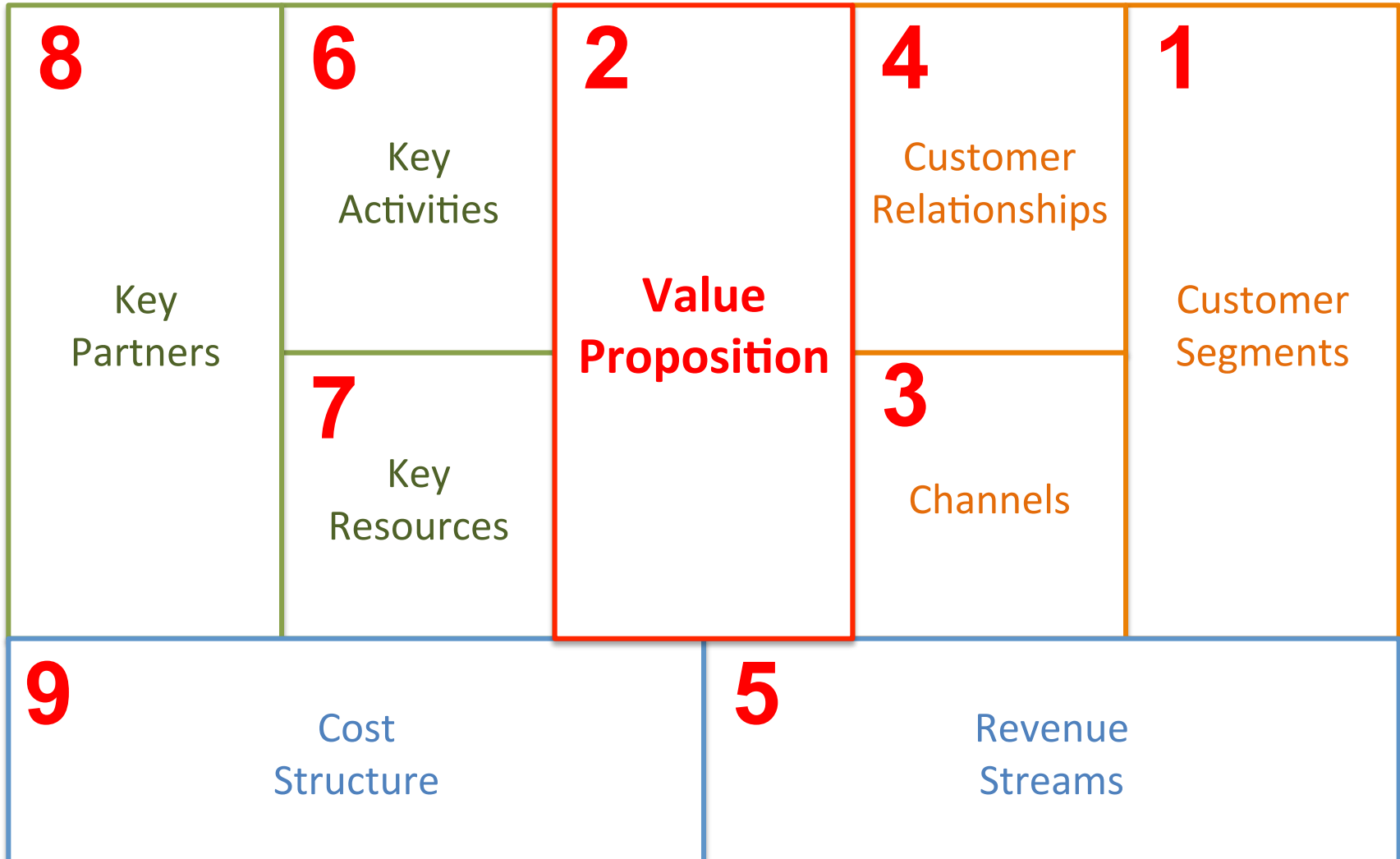

# Business Model Generation



# Business Model Generation

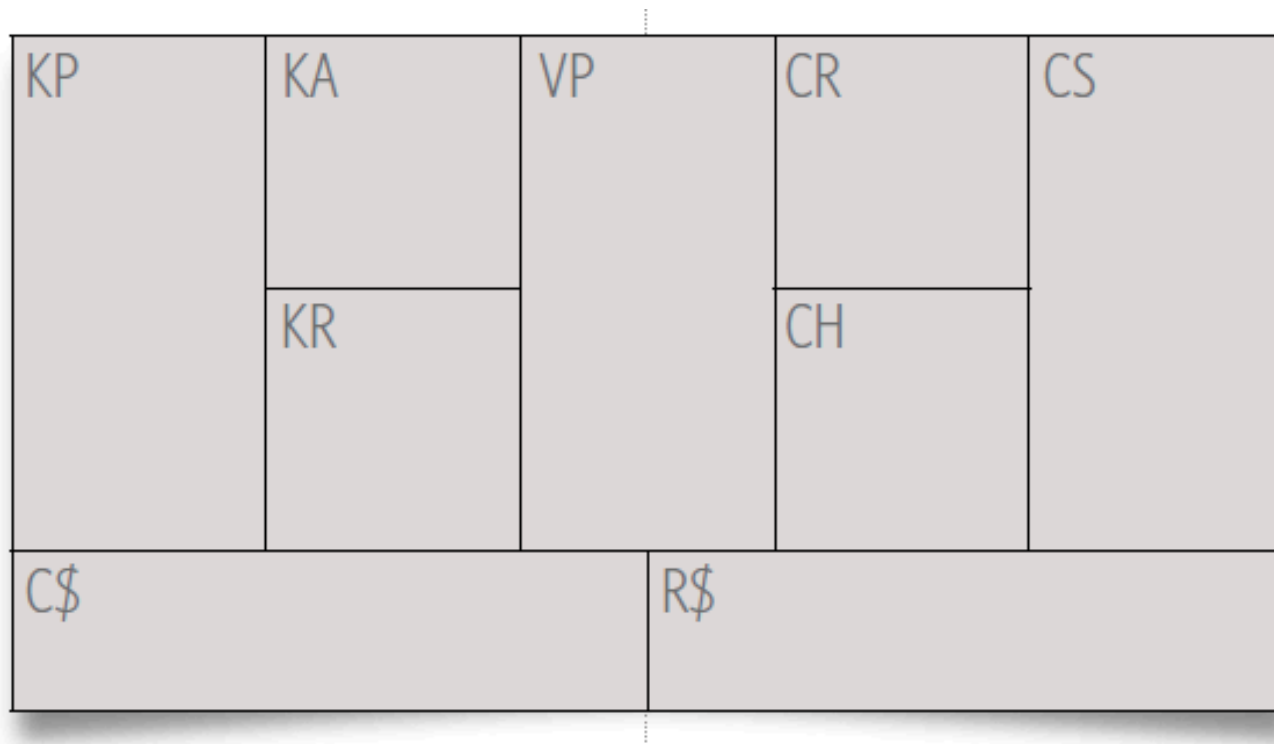

**LEFT CANVAS**  
efficiency

**RIGHT CANVAS**  
value

**Production and Logistics**

Anything beyond content creation is outsourced to readily available service providers.

**Differentiation**

An entirely different format, business model, and story for the book makes it stand out in a crowded market.

**Community**

The book is co-created with practitioners from around the world who feel ownership thanks to attribution as contributing co-authors.

**Buyers**

Paying customers are not only readers, but co-creators and companies that want customized books for their employees and clients.

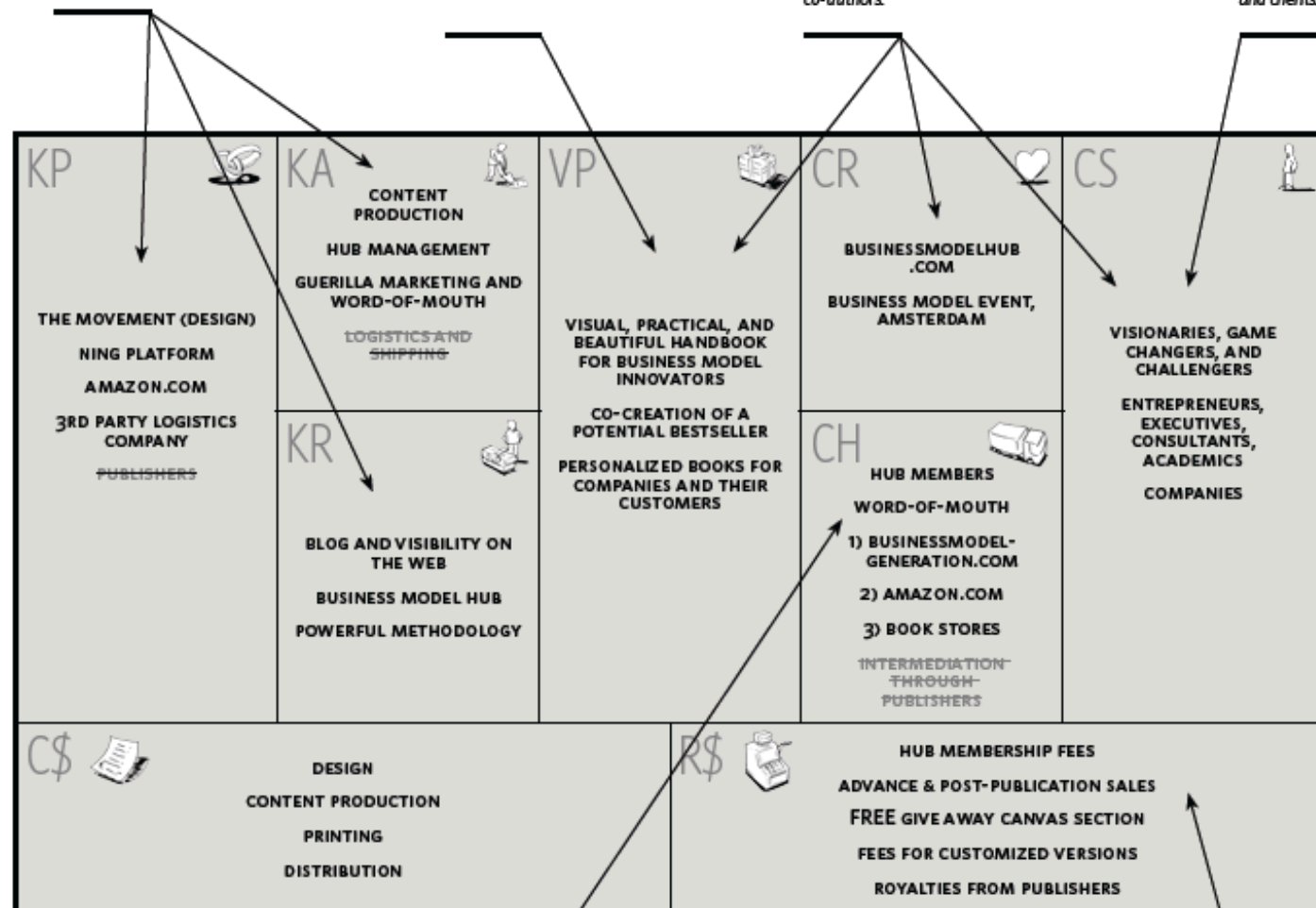

# THE CANVAS OF BUSINESS MODEL GENERATION

**Reach**

A mix of direct and indirect Channels and a phased approach optimizes reach and margins. The story of the book lends itself well to viral marketing and word-of-mouth promotion.

**Revenues**

The book was financed through advanced sales and fees paid by co-creators. Additional revenues come from customized versions for companies and their clients.

# Web 2.0: Social Networking and the Wisdom of Crowds

- **Most popular Web 2.0 service: social networking**
  - Social networking sites sell banner ads, user preference information, and music, videos and e-books
- **Social shopping sites**
  - Swap shopping ideas with friends (Kaboodle, ThisNext)
- **Wisdom of crowds/crowdsourcing**
  - Large numbers of people can make better decisions about topics and products than a single person
- **Prediction markets:**
  - Peer-to-peer betting markets on specific outcomes (elections, sales figures, designs for new products)

# E-commerce marketing

- Internet provides marketers with new ways of identifying and communicating with customers
- Long tail marketing: Ability to reach a large audience inexpensively
- Behavioral targeting: Tracking online behavior of individuals on thousands of Web sites
- Advertising formats include search engine marketing, display ads, rich media, and e-mail

# WEB SITE VISITOR TRACKING

A rectangular button with a dashed border and a light gray background, containing the text "Click 1".

Click 1

The shopper clicks on the home page. The store can tell that the shopper arrived from the Yahoo! portal at 2:30 PM (which might help determine staffing for customer service centers) and how long she lingered on the home page (which might indicate trouble navigating the site).

A rectangular button with a dashed border and a light gray background, containing the text "Click 2".

Click 2

A rectangular button with a dashed border and a light gray background, containing the text "Click 3".

Click 3

The shopper clicks on blouses, clicks to select a woman's white blouse, then clicks to view the same item in pink. The shopper clicks to select this item in a size 10 in pink and clicks to place it in her shopping cart. This information can help the store determine which sizes and colors are most popular.

A rectangular button with a dashed border and a light gray background, containing the text "Click 4".

Click 4

A rectangular button with a dashed border and a light gray background, containing the text "Click 5".

Click 5

A rectangular button with a dashed border and a light gray background, containing the text "Click 6".

Click 6

From the shopping cart page, the shopper clicks to close the browser to leave the Web site without purchasing the blouse. This action could indicate the shopper changed her mind or that she had a problem with the Web site's checkout and payment process. Such behavior might signal that the Web site was not well designed.

# WEB SITE PERSONALIZATION



Based on your portfolio and recent market trends, here are some recommendations.

Welcome back, Steve P. Munson. Check out these recommended titles: One Minute Manager  
Leading Change  
Results-Based Leadership

Sarah, Here are the items you want to bid on: Halogen reading lamp  
Portable reading lamp  
LED book reading lamp



# HOW AN ADVERTISING NETWORK SUCH AS DOUBLECLICK WORKS

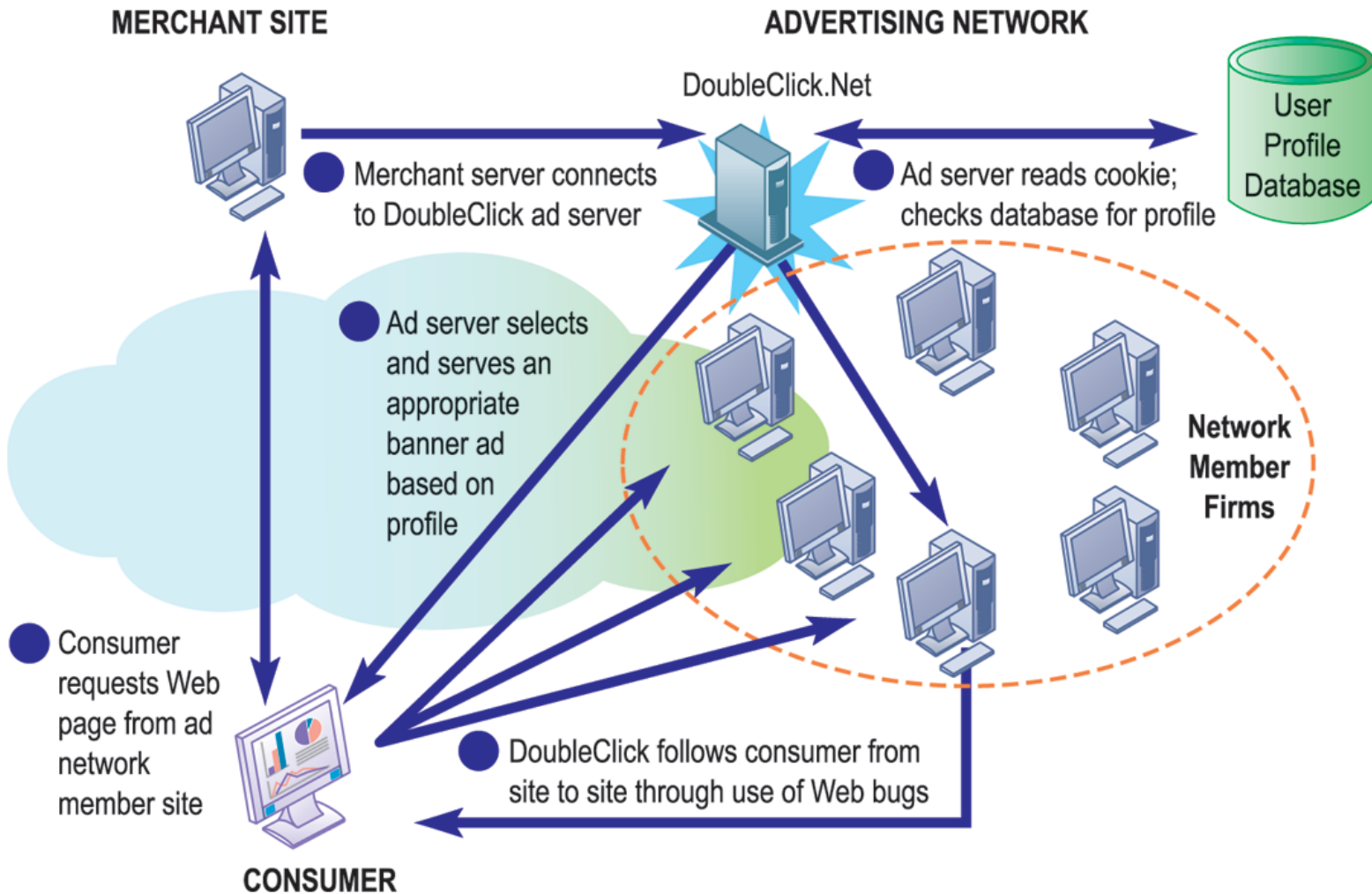

# ELECTRONIC DATA INTERCHANGE (EDI)

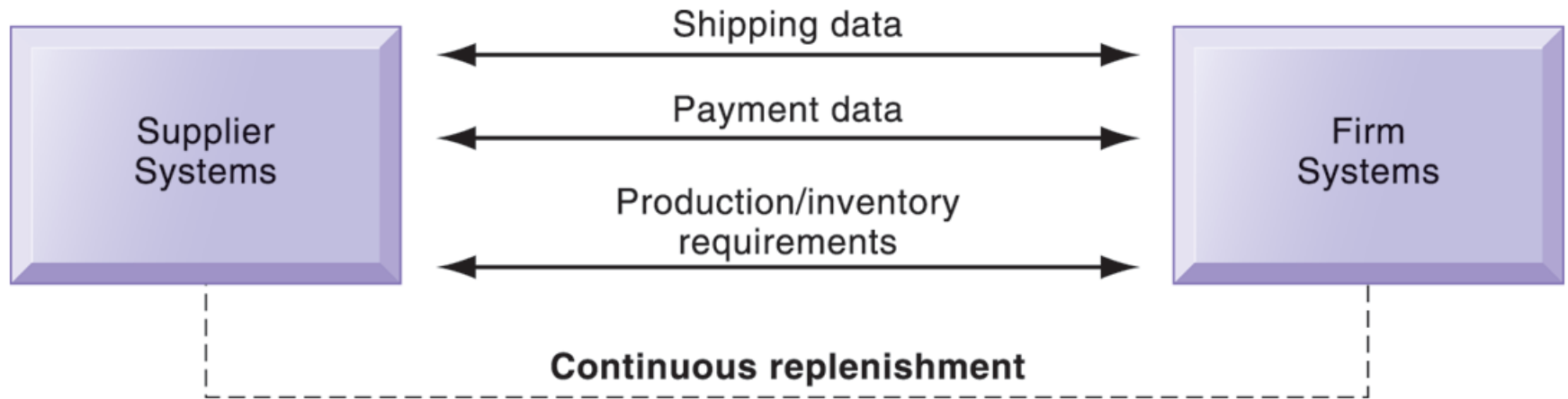

# A PRIVATE INDUSTRIAL NETWORK

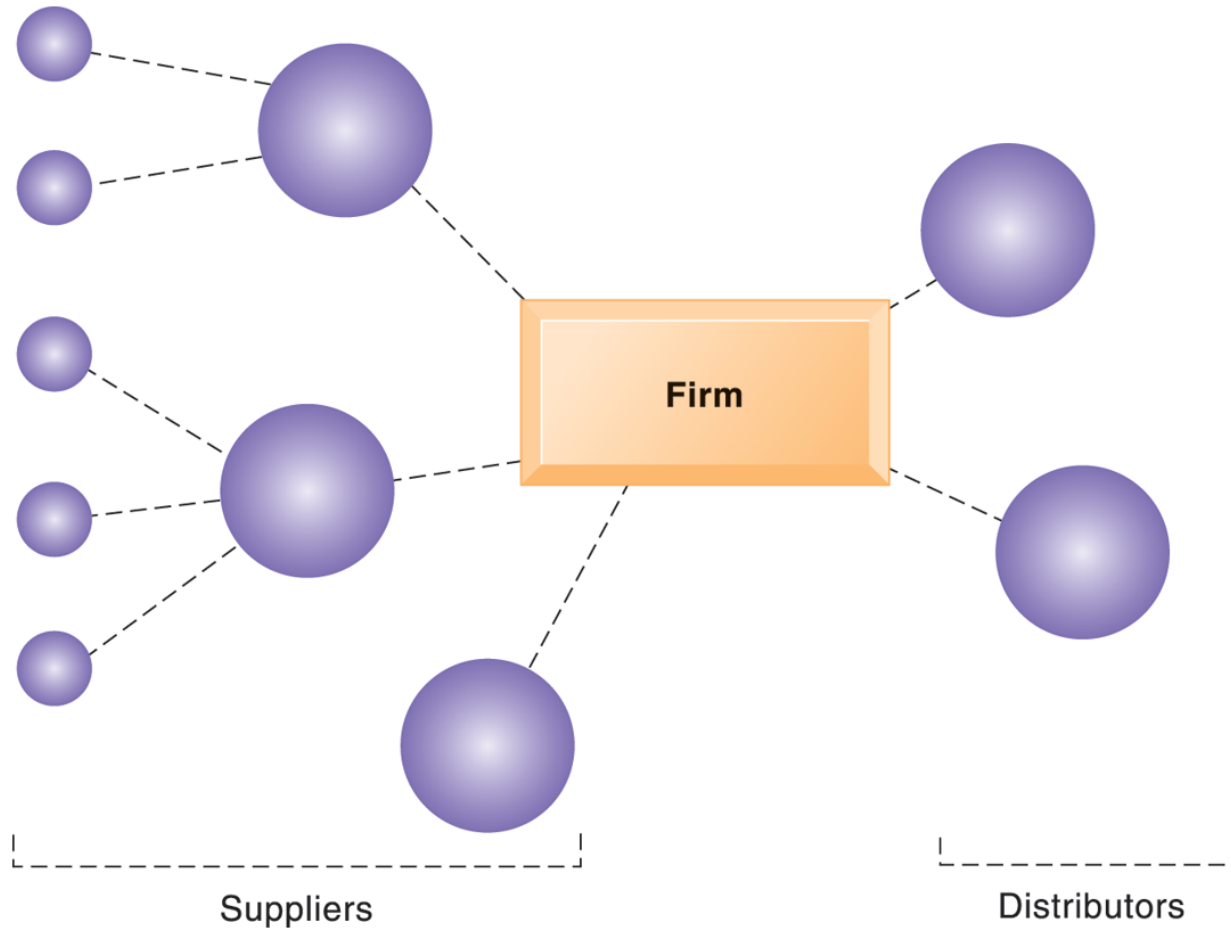

# CONSOLIDATED MOBILE COMMERCE REVENUES

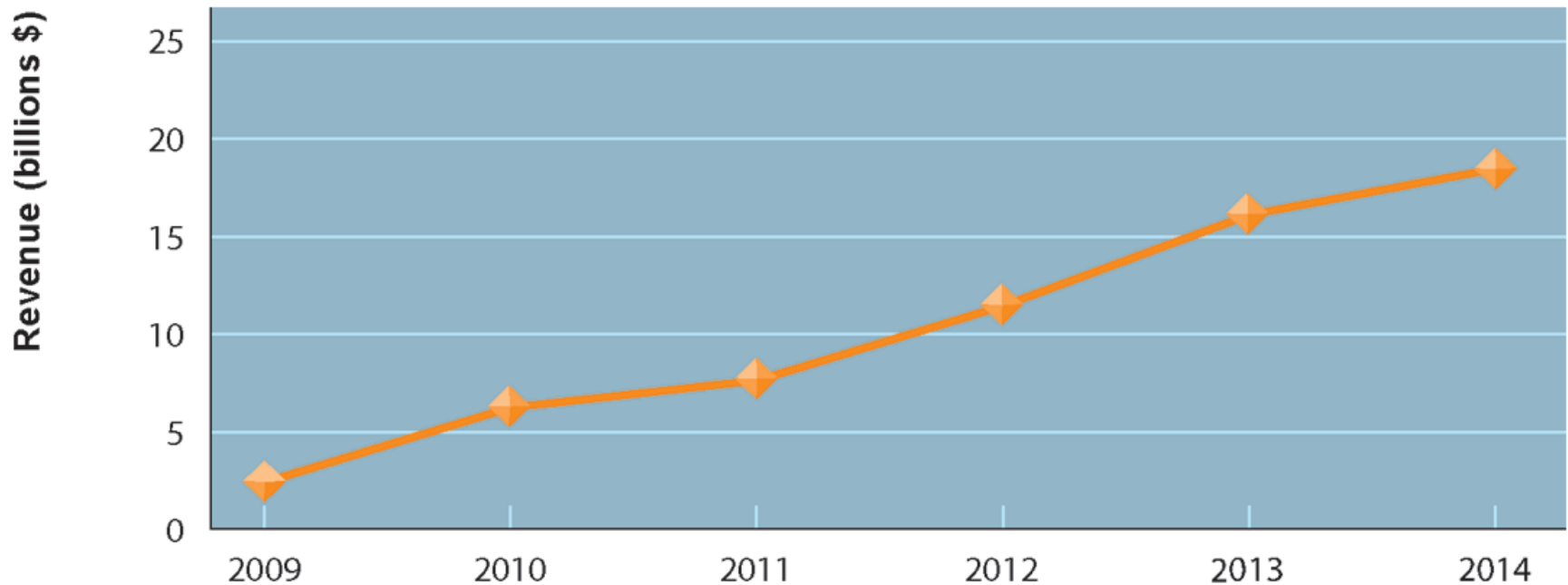

# CHOICES IN BUILDING AND HOSTING WEB SITES

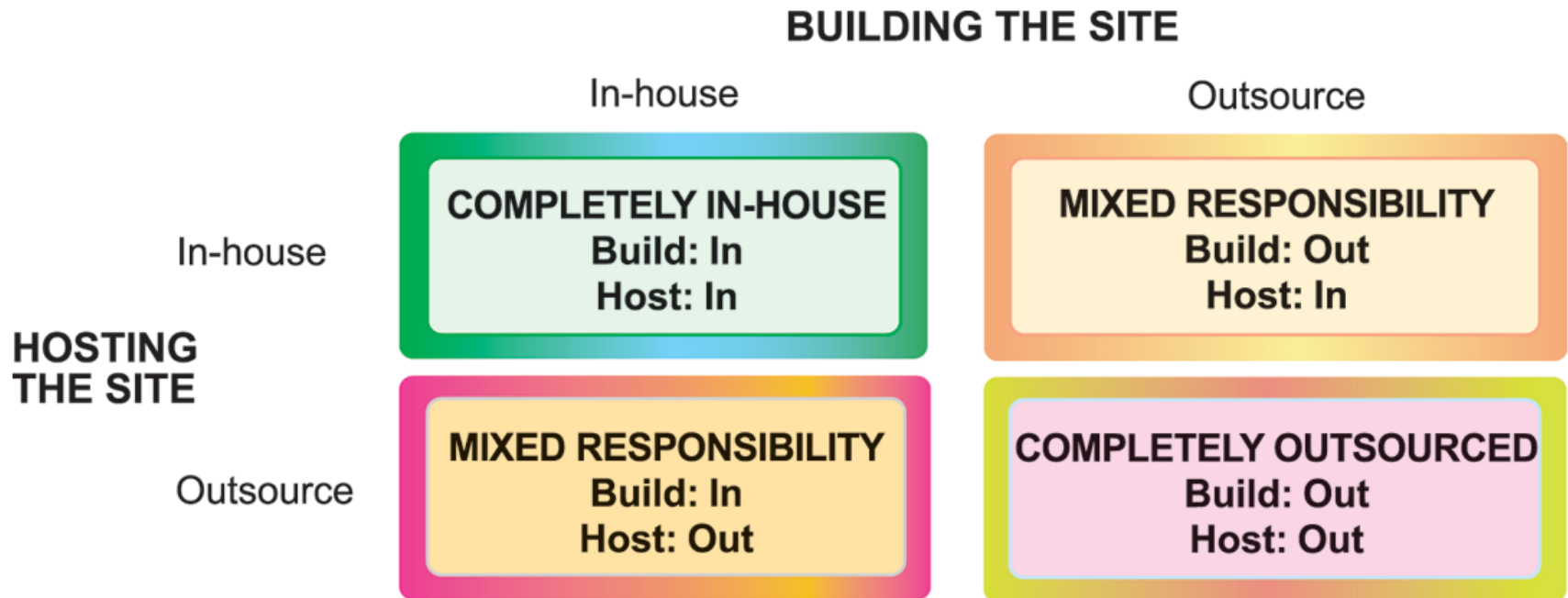

# COMPONENTS OF A WEB SITE BUDGET

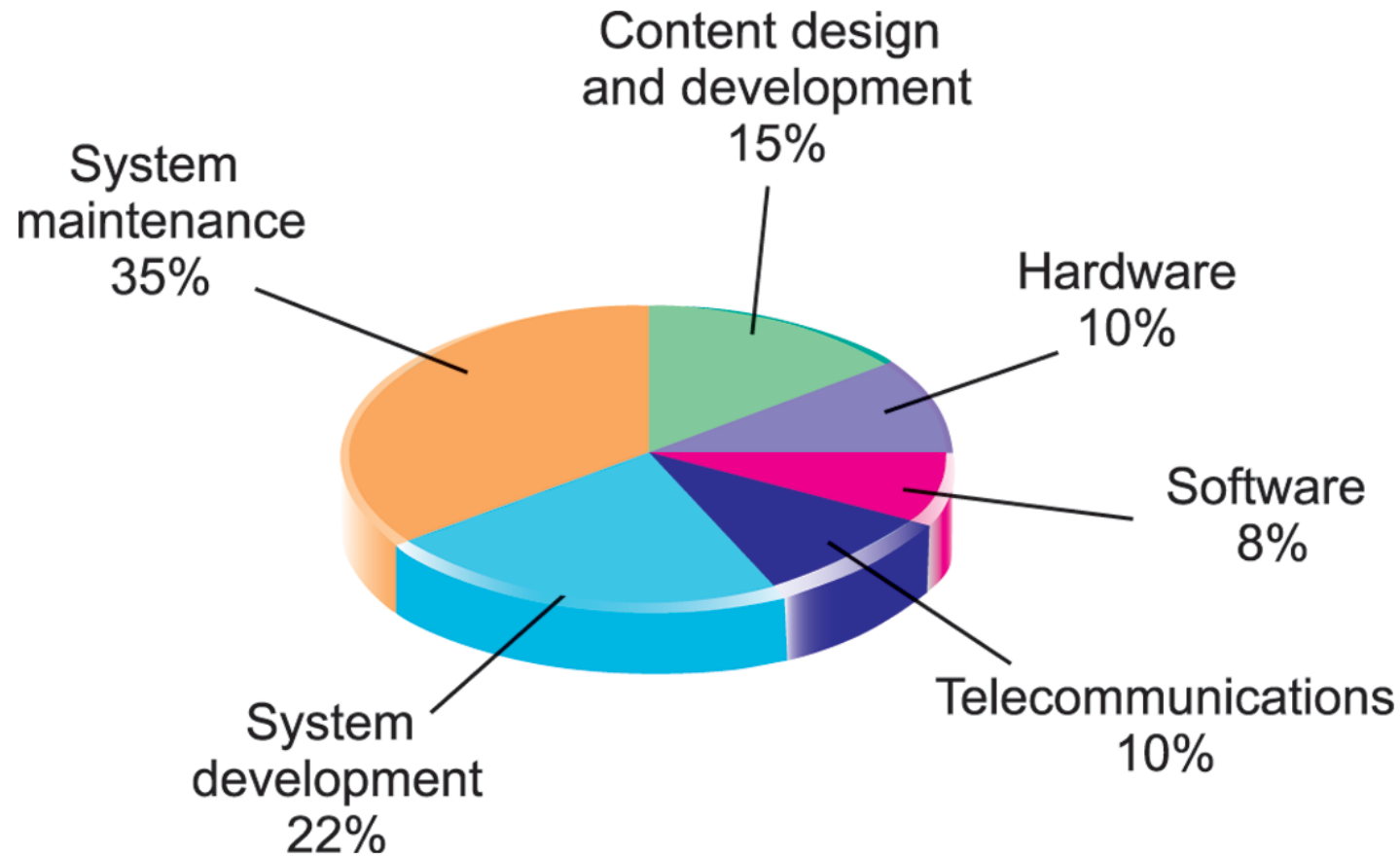

# Case Study: Tata Consulting Services

## Knowledge Management and Collaboration at Tata Consulting Services (Chap. 11)

1. Analyze the knowledge management efforts at Tata Consulting Services (TCS) using the knowledge management value chain model. Which tools or activities were used for managing tacit knowledge and which ones are used for explicit knowledge?
2. Describe the growth of knowledge management systems at TCS? How have these systems helped TCS in its business?
3. Describe the collaboration tools used at TCS? What benefits did TCS reap from these tools?
4. How did Web 2.0 tools help TCS manage knowledge and collaboration among its employees?
5. How do you think KM tools have changed some key operational processes at TCS, such as bidding for new projects, project development and implementation, customer service, and so on?

# 資訊管理個案

## (Case Study for Information Management)

1. 請同學於資訊管理個案討論前  
應詳細研讀個案，並思考個案研究問題。
2. 請同學於上課前複習相關資訊管理相關  
理論，以作為個案分析及擬定管理對策  
的依據。
3. 請同學於上課前  
先繳交個案研究問題書面報告。



# References

- Kenneth C. Laudon & Jane P. Laudon (2012),  
Management Information Systems: Managing the  
Digital Firm, Twelfth Edition, Pearson.
- 周宣光 譯 (2011) ,  
資訊管理系統－管理數位化公司 ,  
第12版 , 東華書局
- Alexander Osterwalder, Yves Pigneur & Christopher L. Tucci  
(2005), “Clarifying Business Models: Origins, Present, and  
Future of the Concept”, Communications of the Association for  
Information Systems (CAIS), Vol. 15, No. 1, May 2005, pp. 1-25.
- Alexander Osterwalder & Yves Pigneur (2010),  
Business Model Generation: A Handbook for Visionaries, Game  
Changers, and Challengers, Wiley.